

Control Valves

PVDF Plastic Control Valve for Corrosive Service

DESCRIPTION

The PVDF Plastic Control Valve for Corrosive Service is available in 1/4 in., 1/2 in., 3/4 in. and 1 in. sizes. Its compact design and light weight make it especially suited for modulating control of low to medium flow rates.

APPLICATION

These valves are widely used in industries such as:

- Water treatment
- Chemical feed
- PH control
- Pilot plants
- Semiconductor
- Pulp and paper

FEATURES

- Available in 1/4-inch, 1/2-inch, 3/4-inch and 1-inch sizes
- Linear or equal percent trims
- PVDF, Hast-C, tantalum trims
- Kynar trim CVs from 0.05...6.0
- Metallic trim CVs from 0.003...6.0
- NPT or wafer style connections
- Teflon CV rings or REK packing
- Pneumatic and electric actuators
- Stainless steel pneumatic actuators

TYPICAL FLUIDS

- Sodium hypochlorite
- Caustic (NaOH)
- Chlorine dioxide
- Sulfuric acid
- Sodium chlorate
- Bromine
- Hydrofluoric
- Ammonium fluoride
- Carbon tetrachloride
- Perchlroethylene
- Hydrogen chloride
- Hydrochloric acid



END FITTING AVAILABILITY

Body Size	NPT	Wafer ANSI 3/4 in. 150 RF	Wafer ANSI 1 in. 150 RF	Trim Types
1/4 in.	X			M
1/2 in.	X		X	M, P
3/4 in.	X	X	X	M, P
1 in.			X	M, P

M-Metallic, P-Plastic

Temperature	Pressure
150° F	75 psi
75° F	150 psi
0° F	150 psi

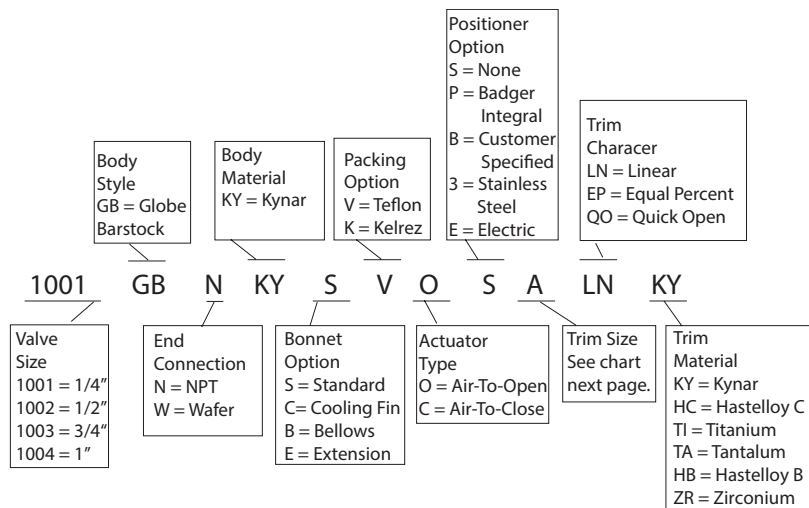

TRIM CHART

Valve Size	Trim Designation	Max Cv	Orifice Dia. (in.)	Orifice Area (sq. in.)	Nominal Rangeability	
					Linear	Equal %
1 in.	6.0	6.0	0.6250	0.3068	50:1	60:1
	5.0	5.0	0.6250	0.3068	50:1	60:1
	4.5	4.5	0.5000	0.1963	50:1	60:1
3/4 in. and 1 in.	4.0	4.0	0.4375	0.1503	50:1	60:1
	3.5	3.5	0.4375	0.1503	50:1	60:1
1/2 in., 3/4 in. and 1 in.	A	2.5	0.3750	0.1104	40:1	50:1
	B	2.0	0.3750	0.1104	40:1	50:1
	C	1.25	0.2810	0.0620	40:1	50:1
	D	0.8	0.2500	0.0491	40:1	50:1
	E	0.5	0.2500	0.0491	40:1	50:1
1/4 in., 1/2 in., 3/4 in. and 1 in.	F	0.32	0.1560	0.0191	30:1	40:1
	G	0.2	0.1560	0.0191	30:1	40:1
	H	0.13	0.1560	0.0191	30:1	40:1
	I	0.08	0.1560	0.0191	30:1	40:1
	J	0.05	0.1560	0.0191	30:1	40:1
	K*	0.03	0.0860	0.0058	25:1	NA
	L*	0.02	0.0860	0.0058	25:1	NA
	M*	0.01	0.0860	0.0058	25:1	NA
	N*	0.006	0.0860	0.0058	25:1	NA
	O*	0.003	0.0860	0.0058	25:1	NA

* Reduced trim

CONSTRUCTION

Body/Bonnet	Standard	PVDF
	Optional	PVC
Trim	Standard	Kynar or Alloy C
	Optional	Alloy B
		Tantalum
		Titanium
		Zirconium
Other exotic materials		
Actuator	Standard	Painted aluminum
	Optional	316L (1/2" and larger)
Packing	Standard	TFE chevron rings
	Optional	REK (low emission)

DIMENSIONS

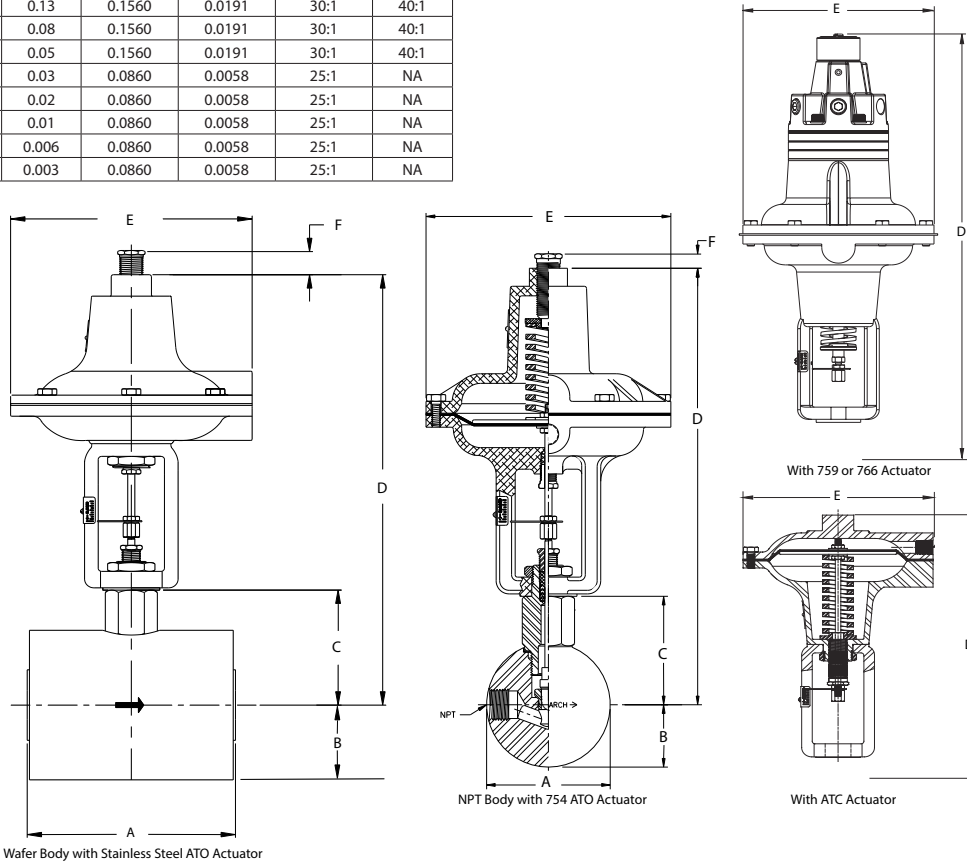

Body Size	Connection	A	B	C	SST ATO	SST ATC	754 ATO	755 ATC	766 w/BLRA	759 w/TLDA	ALL	ATO (Max.)
					D	D	D	D	D	D		F
1/2 in.	NPT	3.3	1.6	2.9	11.9	11.9	11.4	11.3	16.9	16.9	6.4	0.4
1/2 in.	Wafer ANSI 1 in. 150 RF	5.5	2.1	3.2	12.2	12.2	11.8	11.3	16.9	16.9	6.4	0.4
1/2 in.	Wafer ANSI 1 in. 150 RF (Std)	2.5	2.1	3.2	12.2	12.2	11.8	11.3	16.9	16.9	6.4	0.4
3/4 in.	NPT	4.3	2.1	3.9	12.9	12.9	12.5	12.3	17.9	17.9	6.4	0.4
3/4 in.	Wafer ANSI 3/4 in. 150 RF	3.25	2.1	3.9	12.9	12.9	12.5	12.3	17.9	17.9	6.4	0.4
1 in.	Wafer ANSI 1 in. 150 RF	2.5	2.1	3.9	12.9	12.9	12.5	12.3	17.9	17.9	6.4	0.4

Control. Manage. Optimize.

Research Control is a registered trademark of Badger Meter, Inc. Other trademarks appearing in this document are the property of their respective entities. Due to continuous research, product improvements and enhancements, Badger Meter reserves the right to change product or system specifications without notice, except to the extent an outstanding contractual obligation exists. © 2022 Badger Meter, Inc. All rights reserved.