

## Control Valves

### Type HP-10 (10,000 PSI), Globe or Angle

#### DESCRIPTION

The Type HP-10 high pressure control valve is available in 1/4 inch and 1/2 inch line sizes and Globe or Angle configurations. It is especially designed for the control of high pressure liquids and gases.

#### APPLICATIONS

The Type HP-10 valve is widely used in industrial applications, research, and process pilot plants on liquids and gases where pressures are above our standard Type 807 control valve ratings.

#### MATERIALS OF CONSTRUCTION

<b>Standard</b>	316 SST
<b>Optional</b>	Inconel, Monel, Hastelloy C or ASTM equivalent
<b>Innervalue</b>	
<i>Standard</i>	316 SST
<i>Optional</i>	Stellited 316 SST, Monel, Hastelloy C or ASTM equivalent
<b>Packing</b>	
<i>Standard</i>	TFE CV rings
<i>Optional</i>	Graphite, REK
<b>Actuator</b>	Standard-Aluminum
<b>Actuator Type</b>	
<i>Standard</i>	Air-to-open, fail close; Air-to-close, fail open
<i>Optional</i>	Same as above but with top mounted positioner
<b>Signals</b>	
<i>Standard</i>	3...15#, 3...27#, 6...30#
<i>Optional</i>	With positioner; 3...9#, 9...15#
<b>Accessories</b>	Filter regulator, gauges, I/P converter, hand wheel (on 754 or 755 only) limit switches, solenoids

#### STANDARD FEATURES

- Wide range of interchangeable trims
- Choice of linear or equal percent on most trims
- TFE chevron ring packing
- ANSI Class IV shutoff (size "O" and larger)

#### OPTIONAL FEATURES

- AE high pressure fittings
- Socket weld and butt weld ends
- Casing flange
- Globe pattern body
- Graphite packing
- REK packing (Reduced Emissions)



#### PRESSURE/TEMPERATURE 1/4 IN. 316SST

Temperature		Pressure	
°F	°C	psig	bar
75	24	10,000	689
100	38	9700	669
200	93	8350	576
300	149	7575	522
400	204	6900	476
500	260	6400	441
600	316	6100	420
700	371	5850	403
800	427	5700	393
900	482	5600	386
1000	538	5500	379

**HP-10 ANGLE\* HIGH PRESSURE VALVE ASSEMBLY (10,000 PSI)**

**HP-10 Parts and Materials List**

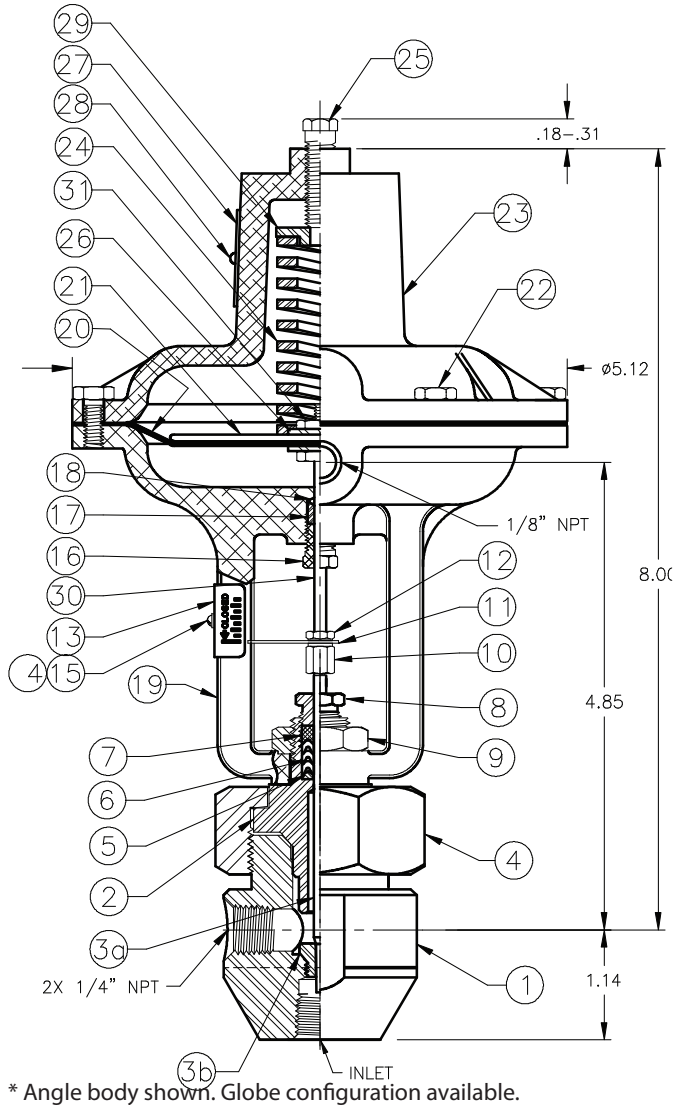

QUANTITIES ARE FOR ONE (1) UNIT ONLY				
ITEM NO.	PART NO.	QTY	DESCRIPTION	MATERIAL
1	527494-00	1	ANGLE BODY	
2	527609-00	1	BONNET	
3a	NOTE 1.	1	INNERVALVE	
3b	NOTE 1.	1	SEAT	
4	500232-00	1	UNION NUT	
5	520580-0019	1	ADAPTOR	PFA
6		1	PACKING	
7	520582-0001	1	FOLLOWER	PFA
8	520581-00	1	PACKING GLAND	
9	520583	1	LOCK NUT	303 SST
10	520997	1	CONNECTOR	300 SER SST
11	510262	1	TRAVEL POINTER	300 SER SST
12	410009	1	STEM NUT	300 SER SST
13	520986-0002	1	TRAVEL SCALE	300 SER SST
14	400001-0072	1	SCREW	300 SER SST
15	430002-0022	1	FLAT WASHER	300 SER SST
16	525025-0001	1	O-RING GLAND	316 SST
17	522761	1	O-RING FOLLOWER	TFE
18	511828	1	O-RING	SILICONE RUBBER
19	520995-0002	1	PRESS CASE & YOKE	ALUMINUM
20	510261-0001	1	DIAPHRAGM	BUNA/ NYLON
21	520994-0001	1	DIAPHRAGM PLATE	STEEL/ ZINC PL
22	400029-0003	6	HEX HD.RIM SCREW	300 SER SST
23	520996-0002	1	SPRING CASE	ALUMINUM
24	510031-0040	1	SPRING	STEEL
25	520990-0002	1	SPRING ADJUSTOR	300 SER SST
26	430002-0037	2	WASHER	300 SER SST
27	512416-0002	1	NAMEPLATE	300 SER SST
28	400018-0012	2	DRIVE SCREW	300 SER SST
29	520991-0001	1	SPRING SEAT	ALUMINUM
30	520992	1	TOPWORKS STEM	316 SST
31	410030-0001	2	LOCKNUT	300 SER SST

**Control. Manage. Optimize.**

Research Control is a registered trademark of Badger Meter, Inc. Other trademarks appearing in this document are the property of their respective entities. Due to continuous research, product improvements and enhancements, Badger Meter reserves the right to change product or system specifications without notice, except to the extent an outstanding contractual obligation exists. © 2021 Badger Meter, Inc. All rights reserved.