

Small Control Valve

U.S. Type 564 (Includes RC230)

DESCRIPTION

The U.S. Type 564 three-way valve is available in either 1/4 in. (DN8) or 1/2 in. (DN15) sizes for modulating control of liquids, gases or steam in either mixing or diverting applications. The unit features one common port and two non-common ports. When used in a diverting application, the common port is piped as the valve inlet with flow proportionally controlled through the two outlet ports. When used in a mixing application, the common port is piped as the outlet with incoming fluid entering the two non-common ports. In this application, the inlet pressure to the two inlets should be the same. Each innervalue within the unit is connected by a common stem and is stroked simultaneously by the actuator. This action causes one orifice to open as the other is closing. The Cv, as well as the characteristic, of each innervalue can be the same or of different values, depending on the requirements of the application.

APPLICATIONS

The Type 564 valve is widely used in mixing applications such as temperature control; for example, when a cold fluid enters one of the non-common ports of the body and a hot fluid enters the other. By varying the position of the innervalue, the percentage of fluid passing through each innervalue can be controlled as it exits the common port. The same concept can be applied to blending of various chemicals, dyes, additives and other fluids or gases that must be proportionally mixed.

The unit is also suited to diverting applications such as flow or pressure control in hydraulic systems. The hydraulic fluid enters the common port of the valve with one of the non-common ports controlling the flow to a cylinder or vessel with the unused fluid re-circulated back to the sump area through the other non-common port.

MATERIALS

Body-Bonnet (Barstock body material)	Standard	316 stainless steel, carbon steel
	Optional	Monel, Hastelloy B and C or ASTM equivalent, alloy 20
Innervalue	Standard	316 stainless steel
	Optional	Monel, Hastelloy B and C or ASTM equivalent, alloy 20, TFE soft seated (Q.O. on-off trim only)
Packing	Standard	TFE CV rings
	Optional	Graphite
Actuator	Standard	Epoxy-coated aluminum
	Optional	316L stainless steel (1/2 in. (DN15) standard unit only)

STANDARD FEATURES

- Wide range of interchangeable trim sets
- Choice of Cv and characteristic on each port
- TFE chevron packing
- ANSI Class III shutoff



Shown with type 755 actuator

OPTIONAL FEATURES

- Flanges: up to 1-1/2 in. (38.1 mm) on 1/2 in. (DN15) valve size, socket weld and butt weld nipples
- Radiating fin bonnet for higher temperatures
- Choice of linear or quick-opening characteristics

ACTUATOR CHOICES

Standard	Air-to-open, fail close Air-to-close, fail open
Optional	Same function as above but with integral top-mounted positioner
Standard Signal	3...15#, 6...30#, 3...27#
Optional Signal	3...9#, 9...13#, (with positioner)
Accessories	Filter regulator, gauges, I/P accessories: converters limit switches, handwheel (non-override), solenoids.

PRESSURE VS TEMPERATURE RATING FOR VALVE SUPERSTRUCTURE

The following tables exclude packing and end fittings:

1/4 in. (DN8) Research Control Valve							
Temp	316 S/S psi (bar)	Carbon Steel psi (bar)	Hastelloy B or = psi (bar)	Hastelloy C or = psi (bar)	Monel psi (bar)	Alloy 20 psi (bar)	Alloy 625 psi (bar)
100° F (37.8° C)	1500 (103)	1500 (103)	1500 (103)	1500 (103)	1200 (83)	1500 (103)	1500 (103)
200° F (93.3° C)	1500 (103)	1500 (103)	1500 (103)	1368 (94)	1049 (72)	1349 (93)	1500 (103)
300° F (148.9° C)	1500 (103)	1500 (103)	1443 (99)	1264 (87)	977 (67)	1290 (89)	1500 (103)
400° F (204.4° C)	1448 (100)	1500 (103)	1381 (95)	1170 (81)	949 (65)	1238 (85)	1469 (101)
500° F (260.0° C)	1350 (93)	1470 (101)	1333 (92)	1093 (75)	941 (65)	1192 (82)	1439 (99)
600° F (315.6° C)	1275 (88)	1380 (95)	1299 (90)	1027 (71)	941 (65)	1159 (80)	1404 (97)
700° F (371.1° C)	1223 (84)	1290 (89)	1271 (88)	978 (67)	934 (64)	1140 (79)	1391 (96)
800° F (426.7° C)	1193 (82)	900 (62)	1232 (85)	940 (65)	913 (63)	1100 (76)	1364 (94)
Recommended torque in ft-lb (Nm), +/- 2 ft-lb (2.71 Nm)							
Bonnet	37 (50)	37 (50)	39 (53)	37 (50)	31 (42)	35 (47)	39 (53)
Bottom Adapt.	123 (167)	123 (167)	132 (179)	125 (169)	103 (140)	123 (167)	132 (179)

1/2 in. (DN15) Research Control Valve							
Temp	316 S/S psi (bar)	Carbon Steel psi (bar)	Hastelloy B or = psi (bar)	Hastelloy C or = psi (bar)	Monel psi (bar)	Alloy 20 psi (bar)	Alloy 625 psi (bar)
100° F (37.8° C)	1500 (103)	1500 (103)	1500 (103)	1500 (103)	1200 (83)	1500 (103)	1500 (103)
200° F (93.3° C)	1500 (103)	1500 (103)	1500 (103)	1368 (94)	1049 (72)	1349 (93)	1500 (103)
300° F (148.9° C)	1500 (103)	1500 (103)	1443 (99)	1264 (87)	977 (67)	1290 (89)	1500 (103)
400° F (204.4° C)	1448 (100)	1500 (103)	1381 (95)	1170 (81)	949 (65)	1238 (85)	1469 (101)
500° F (260.0° C)	1350 (93)	1470 (101)	1333 (92)	1093 (75)	941 (65)	1192 (82)	1439 (99)
600° F (315.6° C)	1275 (88)	1380 (95)	1299 (90)	1027 (71)	941 (65)	1159 (80)	1404 (97)
700° F (371.1° C)	1223 (84)	1290 (89)	1271 (88)	978 (67)	934 (64)	1140 (79)	1391 (96)
800° F (426.7° C)	1193 (82)	—	—	—	—	—	—
Recommended torque in ft-lb (Nm), +/- 2 ft-lb (2.71 Nm)							
Bonnet	122 (165)	122 (165)	131 (178)	124 (168)	102 (138)	117 (159)	131 (178)
Bottom Adapt.	200 (271)	200 (271)	308 (418)	293 (397)	241 (327)	244 (304)	308 (418)

NOTE: The pressure vs temperature ratings listed above are based on material cross sections at the joint between the body and bonnet where a gasketed screwed type bonnet is used. When the proper torque levels are used, the valve should not experience rupture of the joint or the material. The torque levels listed above were used in hydrostatic tests at the factory at 70° F (21.1° C) at maximum body rating and were found to provide acceptable sealing. Other factors such as high or cyclic temperatures, light process gases or poor gasket surfaces can dictate the ability of a seal being made. Under such conditions, the only way to make sure there is a tight seal is to perform a test under the actual process conditions.

NOTE: The maximum temperature rating for carbon steel is 750° F (398.9° C). The pressure rating of the 1/4 in. (DN8) valve at 750° F (398.9° C) is 750 psi.

DIMENSIONS

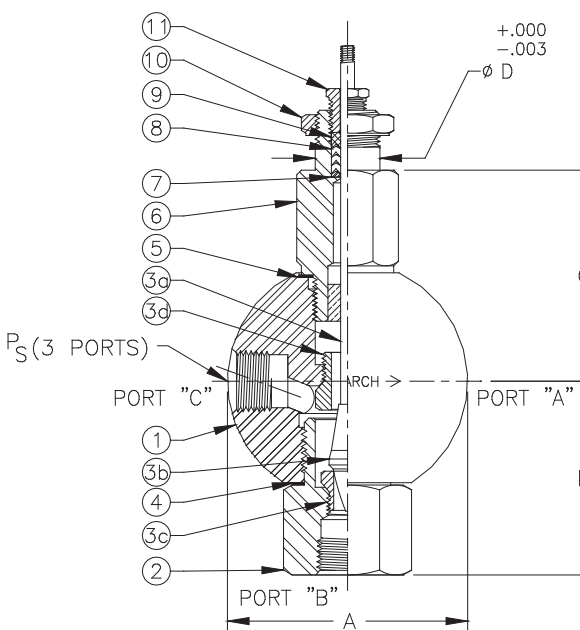

- Valve body (barstock, NPT ends standard)
- Bottom body adapter (1/4 in. (DN8) valve = 1-1/4 in. (31.8 mm) hex; 1/2 in. (DN15) valve = 1-1/2" hex)
- Innervalve (trim set)
 - Plug (throttling portion)
 - Lower seat (1/4 in. (DN8) valve = 3/8 in. (9.5 mm) hex; 1/2 in. (DN15) valve = 5/8 in. (15.9 mm) hex)
 - Upper seat (1/4 in. (DN8) valve = 5/8 (15.9 mm) hex; 1/2 in. (DN15) valve = 3/4 in. (19.1 mm) hex)
 - Stem (1/4 in. (DN8) valve = 1/8 in. (3.2 mm) dia.; 1/2 in. (DN15) valve = 3/16 in. (4.8 mm) dia.)
- Bottom port adapter gasket (may not be supplied in exotic materials)
- Bonnet gasket (may not be supplied in exotic materials)
- Valve bonnet (1/4 in. (DN8) valve = 7/8 in. (22.2mm) hex; 1/2 in. (DN15) valve = 1-1/4 in. (31.8 mm) hex. some exotic materials may use round material)
- Packing adapter (CV ring packing only)
- Packing (CV Ring TFE)
- Packing follower (CV ring packing only)
- Yoke lock nut (1/4 in. (DN8) valve = 7/8 in. (22.2 mm) hex; 1/2 in. (DN15) valve = 1-1/8 in. (28.6 mm) hex)
- Packing gland (1/4 in. (DN8) valve = 7/16 in. (11.1 mm) hex; 1/2 in. (DN15) valve = 1/2 in. (12.7 mm) hex)

Dimensions					
PS in. (mm)	A in. (mm)	B in. (mm)	C in. (mm)	D in. (mm)	Stroke
1/4 (6.4)	2.75 (69.8)	2.00 (50.8)	2.12 (53.8)	0.625 (15.9)	0.437
1/2 (12.7)	3.25 (82.5)	2.62 (66.5)	2.86 (72.9)	0.875 (22.2)	0.562

INNERVALVE CHART

While three-way valves can be used in mixing and diverting applications, the characteristics are based on mixing. Equal percentage trims are not recommended on three-way valves.

Valve Size	Trim Designation*	Nominal CV	Orifice Dia	Orifice Area	Nominal Rangeability Linear	Max Pressure Drop**
1/2 in. (DN15)	A Lwr Seat	2.5	0.3750 (9.5 mm)	0.1104 in. ² (71.2 mm ²)	40:1	50 psi
	A Upr Seat	2.5	0.4375 in. (11.1 mm)	0.1504 in. ² (97.0 mm ²)	40:1	50 psi
	B Lwr Seat	2.0	0.3750 (9.5 mm)	0.1104 in. ² (71.2 mm ²)	40:1	50 psi
	B Upr Seat	2.0	0.4375 in. (11.1 mm)	0.1504 in. ² (97.3 mm ²)	40:1	50 psi
	C Lwr Seat	1.25	0.2810 (7.1 mm)	0.0621 in. ² (40.1 mm ²)	40:1	100 psi
	C Upr Seat	1.25	0.3125 in. (7.9 mm)	0.0767 in. ² (49.5 mm ²)	40:1	100 psi
	D Lwr Seat	0.80	0.250 in. (6.4 mm)	0.0491 in. ² (31.7 mm ²)	40:1	150 psi
	D Upr Seat	0.80	0.2810 (7.1 mm)	0.0621 in. ² (40.1 mm ²)	40:1	100 psi
	E Lwr Seat	0.50	0.250 in. (6.4 mm)	0.0491 in. ² (31.7 mm ²)	40:1	150 psi
	E Upr Seat	0.50	0.2810 (7.1 mm)	0.0621 in. ² (40.1 mm ²)	40:1	150 psi
	F Lwr Seat	0.32	0.1560 in. (3.9 mm)	0.0191 in. ² (12.3 mm ²)	30:1	300 psi
	F Upr Seat	0.32	0.2810 (7.1 mm)	0.0621 in. ² (40.1 mm ²)	30:1	300 psi
	G Lwr Seat	0.20	0.1560 in. (3.9 mm)	0.0191 in. ² (12.3 mm ²)	30:1	300 psi
	G Upr Seat	0.20	0.2810 (7.1 mm)	0.0621 in. ² (40.1 mm ²)	30:1	300 psi
	H Lwr Seat	0.13	0.1560 in. (3.9 mm)	0.0191 in. ² (12.3 mm ²)	30:1	300 psi
	H Upr Seat	0.13	0.2810 (7.1 mm)	0.0621 in. ² (40.1 mm ²)	30:1	300 psi
1/4 in. (DN8)	I Lwr Seat	0.08	0.1560 in. (3.9 mm)	0.0191 in. ² (12.3 mm ²)	30:1	300 psi
	I Upr Seat	0.08	0.2810 (7.1 mm)	0.0621 in. ² (40.1 mm ²)	30:1	300 psi
	J Lwr Seat	0.05	0.1560 in. (3.9 mm)	0.0191 in. ² (12.3 mm ²)	30:1	300 psi
	J Upr Seat	0.05	0.2810 (7.1 mm)	0.0621 in. ² (40.1 mm ²)	30:1	300 psi
	F Lwr Seat	0.32	0.1560 in. (3.9 mm)	0.0191 in. ² (12.3 mm ²)	30:1	200 psi
	F Upr Seat	0.32	0.250 in. (6.4 mm)	0.0491 in. ² (31.7 mm ²)	30:1	200 psi
	G Lwr Seat	0.20	0.1560 in. (3.9 mm)	0.0191 in. ² (12.3 mm ²)	30:1	200 psi
	G Upr Seat	0.20	0.250 in. (6.4 mm)	0.0491 in. ² (31.7 mm ²)	30:1	200 psi
	H Lwr Seat	0.13	0.1560 in. (3.9 mm)	0.0191 in. ² (12.3 mm ²)	30:1	200 psi
	H Upr Seat	0.13	0.250 in. (6.4 mm)	0.0491 in. ² (31.7 mm ²)	30:1	200 psi
I Lwr Seat	0.08	0.1560 in. (3.9 mm)	0.0191 in. ² (12.3 mm ²)	30:1	200 psi	
I Upr Seat	0.08	0.250 in. (6.4 mm)	0.0491 in. ² (31.7 mm ²)	30:1	200 psi	
J Lwr Seat	0.05	0.1560 in. (3.9 mm)	0.0191 in. ² (12.3 mm ²)	30:1	200 psi	
J Upr Seat	0.05	0.250 in. (6.4 mm)	0.0491 in. ² (31.7 mm ²)	30:1	200 psi	

* Due to the area taken up by the stem, the orifice diameter of the upper seat is larger than that of the lower seat for the same size trim.

**The maximum pressure drop limit should not be exceeded without consulting the factory. In some cases, the use of special stem guides and materials can raise the pressure drop limit.

Control. Manage. Optimize.

Research Control is a registered trademark of Badger Meter, Inc. Other trademarks appearing in this document are the property of their respective entities. Due to continuous research, product improvements and enhancements, Badger Meter reserves the right to change product or system specifications without notice, except to the extent an outstanding contractual obligation exists. © 2021 Badger Meter, Inc. All rights reserved.

www.badgermeter.com