

DESCRIPTION

The Model EVA-1 is a small, electronically controlled valve actuator developed specifically to fit 1/4...1 in. (6...25 mm) Research Control Valves. Its accurate positioning and compact size make it especially suited to flow control in research and small process applications. The unit features:

- Microprocessor-controlled, linear stepper motor
- 4...20 mA analog input
- Position 4...20 mA analog output (optional)
- Choice of 12 speeds
- Up to 40 pounds of stem thrust
- Accurate and repeatable positioning
- Adjustable split range
- Quick and simple zero and span input and output adjustments
- Adjustable stroke range 0.1875...0.5625 in. (4...14 mm)
- User adjustable direct or reverse action
- RS-232 Serial Port for all adjustments without removing the cover*
- Controlled seating force to prevent innervalve damage
- Built-in temperature compensation
- Stainless steel yoke and rugged epoxy coated aluminum housing
- 115V AC/12V DC, 230V AC/12V DC, and 24V DC models available

* Not Explosion Proof when RS-232 port is uncovered or when cover is removed.

OPERATION

The Model EVA-1 consists of a microprocessor-controlled, linear stepper motor that responds to an input signal of 4...20 mA DC. It also has an optional isolated loop powered 4...20 mA position output for signaling back to an indicator or control panel. The standard Model EVA-1 requires a 115V AC power supply with 230V AC and 24V DC models available. A stroke of 0.437 in. (11 mm) for the 1/4 in. (6 mm) unit or a stroke of 0.562 in. (14 mm) for the 1/2...1 in. (12...25 mm) units is standard and can be adjusted quickly and easily with two switches under the actuator cover or via the communication port. This ease of calibration can be used to split range the input or limit the up or down travel of the valve. The unit uses a dual speed operating mode. The low speed mode generates high thrust for seating the valve and overcoming packing friction while the high speed mode allows the valve to respond quickly to large input signal changes.



RATINGS

- NEMA 4, Watertight
- Explosion Proof * Class 1, Division 1, Group C & D
- Standard models approved by FM and CSA

* Not Explosion Proof when RS-232 port is uncovered or when cover is removed.

SPECIFICATIONS

Electrical

Supply Power/Standard	115V AC +/- 10% @ 50...60 Hz and/or 12V DC
Supply Power/Optional	230V AC +/- 10% @ 50...60 Hz and/or 12V DC 24V DC +/- 3%
Control input	4...20 mA DC @ 125 ohms
Position Output	4...20 mA DC isolated, 0...800 ohm loop impedance

Mechanical

Stroke Length	Up to 0.562 in. (143 mm) (adjustable)
Thrust	40 lb (18.1 kg) at minimum step rate; 10 lb (4.5 kg) at maximum step rate See "Specifications" on page 2
Height	13 in. (330.2 mm) (actuator with yoke only)
Weight	12 lb (5.4 kg) (actuator with yoke only)
Operating Temperature Range	14...140° F (-10...60° C)

DIMENSIONS

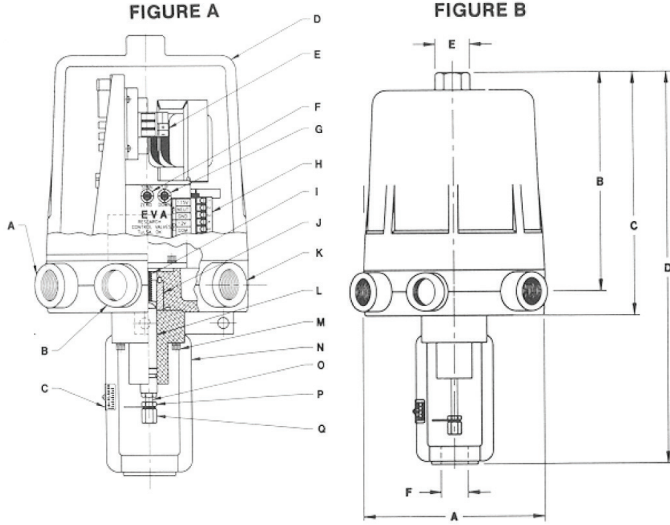

Description of Items

- A: Setup/service port (1/2 in. NPT)
- B: Signal port (1/2 in. NPT)
- C: Travel scale
- D: Cover
- E: Input terminal block (4...20 mA)
- F: Span/zero switch
- G: Travel switch
- H: Power supply board
- I: Motor shaft
- J: Anti-rotation sleeve
- K: Supply power port (1/2 in. NPT)
- L: Spring loaded stem assembly
- M: Cap screw
- N: Yoke
- O: Actuator stem connector
- P: Travel pointer locknut
- Q: Trim stem connector

Valve Size in. (mm)	Dimensions in. (mm)						
	A	B	C	D	E	F	Stroke
1/4 (6.4)	6.18 (157.0)	6.93 (176.0)	7.0 (177.8)	12.19 (309.6)	1.13 (28.7) HEX	0.625 (15.9)	0.437 (11.1)
1/2 (12.7), 3/4 (19.1), 1 (25.4)	6.18 (157.0)	6.93 (176.0)	7.0 (177.8)	12.31 (312.7)	1.13 (28.7) HEX	0.875 (22.2)	0.562 (14.3)

SPECIFICATIONS

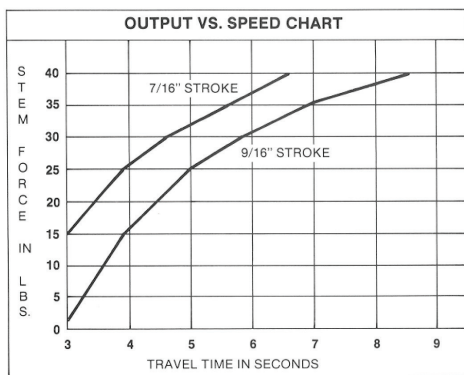

Control. Manage. Optimize.

Research Control is a registered trademark of Badger Meter, Inc. Other trademarks appearing in this document are the property of their respective entities. Due to continuous research, product improvements and enhancements, Badger Meter reserves the right to change product or system specifications without notice, except to the extent an outstanding contractual obligation exists. © 2020 Badger Meter, Inc. All rights reserved.

CALIBRATION PROCEDURE

1. Input Zero: With P1 jumper set to the *Normal* position, apply input signal for the *Closed* valve position. Use the **Up/Down** switch to close the valve. Push the **Span/Zero** switch to *Zero*.
2. Input Span: Apply input signal for the *Open* valve position. Use the **up/down** switch to open the valve. Push the **Span/Zero** switch to *Span*.
3. Output Zero*: Apply input signal for the *Closed* valve position. Move P1 jumper to the *Zero* position. Adjust the output to read 4 mA with the **Up/Down** switch. Push the **Span/Zero** switch to *Zero*.
4. Output Span*: Apply input signal for the *Open* valve position. Move **P1 jumper** to the *Span* position. Adjust the output to read 20 mA with the **Up/Down** switch. Push the **Span/Zero** switch to *Span*.
5. Return **P1 Jumper** to the *Normal* position.

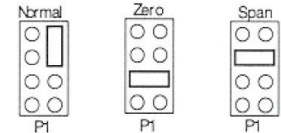

NOTE: P1 is located on the electronic logic card.

*Optional feature.

WIRING CONNECTIONS

Power Supply Terminal Block

See item H of Dimensions figure.



- 115V AC 230V AC (Opt.)
- Neutral AC Voltage
- Ground

- 12V DC* 24V DC (Opt.)
- DC Common

AC

DC

*12V DC Std. on AC Units, NA on 24V DC.

Input Terminal Block

See item E of of Dimensions figure.

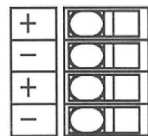

Position Output

(Optional feature)
4...20 mA DC isolated

OUT

Signal Input
4...20 mA DC

IN