



O & M Manual



D12-17 % LEL Gas Transmitter

Home Office

Analytical Technology, Inc.
6 Iron Bridge Drive
Collegeville, PA 19426
Phone: 800-959-0299
610-917-0991
Fax: 610-917-0992
Email: sales@analyticaltechnology.com
Web: www.Analyticaltechnology.com

European Office

ATI (UK) Limited
Unit 1 & 2 Gatehead Business Park
Delph New Road, Delph
Saddleworth OL3 5DE
Phone: +44 (0)1457-873-318
Fax: + 44 (0)1457-874-468
Email: sales@atiuk.com



Table Of Contents

INTRODUCTION _____ 5

COMPONENTS..... 5

- D12 LEL Transmitter5
- The Combustible Gas Sensor5
 - Active Element 5
 - Reference Element..... 5
 - Auto-test Option 5
 - Gas Mixtures 6
 - LEL, UEL..... 6
 - %LEL 6
 - OTM Gases (Other Than Methane) 6
 - Multiple Gas Safety 7
 - Oxygen is Essential..... 7
 - Gas Flooding..... 7
 - Compounds to Avoid 7

SPECIFICATIONS _____ 8

INSTALLATION _____ 9

MECHANICAL MOUNTING..... 9

- Transmitter9

ELECTRICAL CONNECTIONS 11

- The Stack..... 11
- External Power Supply..... 11
- Power Supply Board 12
 - Relay Contacts 13
- Wiring Examples 14
 - ATI A17/B14, 3-Wire Mode..... 14
 - Power Without 4-20mA Signaling 15
 - 4-20mA Signaling, Single Supply, 3-Wire Mode 16
 - 4-20mA Signaling, Dual Supply, 4-Wire Mode 17
 - HART Transmitter, Point-to-Point, 3-Wire (Active Source). 18
 - HART Transmitter, Multi-drop, 3-Wire (Active Source)..... 19
 - RS485 Modbus Multidrop 20
 - RS232 Modbus, PC Capture, or Printer 21
- Remote Sensor Wiring 22
- CPU Board Configuration..... 23

OPERATION _____ 24

OPERATOR INTERFACE..... 24

- Interface Panel..... 24
 - D12 GAS TRANSMITTER 24
- Startup Review Sequence..... 25

- Main Display Page 26
 - Five-minute Time-out Rule..... 26
 - Esc Key Operation (Main Display Page) 26
 - Fault Indication (Main Display Page) 26
- Main Reading..... 27
- Variable Editing..... 28

SENSORS AND GENERATORS 29

- Sensor Setup 29
 - Sensor Setup Page..... 29
 - Sensor More Page 30
 - Sensor More Page 30
- Bump-Testing 31
- Calibration..... 32
 - Calibration Frequency 32
 - Calibration Terminology 32
 - Zero Calibration 32
 - Span Calibration 32
 - Calibration Kits..... 32
 - Indications During Sensor Calibration 32
 - Calibration Exceptions 32
 - Zero Calibration Procedure 33
 - Span Calibration Procedure 34
 - Spanning for OTM Gases (Other Than Methane)..... 35
 - Spanning for Safety – Combustible Sensor Only..... 35
- Sensor Calibration Records 36
- Auto-test 37
 - Auto-test Control Page..... 38
 - Auto-test Setup Page 38
 - Auto-test Setup Options Page..... 39
 - Next Auto-test Page 39
 - Auto-test History Page 40
 - Gas Generator Page..... 40
 - Auto-test Sequence 40

ALARMS AND RELAYS..... 42

- Gas Concentration Alarms 42
 - Manual Alarm Reset 42
 - Remote Reset..... 42
 - Gas Alarm Setup Pages..... 43
 - Alarm Variable Functions 46
- Fault Alarms..... 47
 - Corrective Actions..... 47
 - Alarm Relays 50
 - Relay Setup Page 51
 - Testing Alarm Relays 51
 - Relay Test Page 51
- Inhibiting Alarms 52
 - Alarm Inhibit Setup page..... 52

4-20MA OUTPUT 53

- Output Overrides..... 53
- 4-20mA Setup Page..... 53
- 4-20mA Control Page..... 54
- Loop Adjustment 54

DATA LOG 55

- Data-log Access Page..... 55
- Data-log Setup Page..... 55
- Data-log Graphic Report Page 56
- Data-log Tabular Report Page 56



Data-log Printout 57

DISPLAY..... 58

 Display Setup Page..... 58

SYSTEM..... 59

 System Access Page 59

 Real-time Clock.....59

 Clock Setup Page..... 59

 Security60

 Security Control Page 60

 Activating Security..... 60

 Deactivating Security..... 61

 Changing the Password 61

 Communications62

 Communication Setup Page..... 62

 ASCII 63

 HART 63

 Modbus 65

 Transmitter Version.....65

 Restart66

 Resets.....66

SPARE PARTS 67

APPENDIX A. 68

PRINTING DATA LOG REPORTS 68

 Serial Connection.....68

 Communication Setup Page 68

 Flow Control.....68

 Report Format.....69

 Report Control 69

EXAMPLE: CHARTING A DATA LOG REPORT 70

 Starting the Report.....73

 Charting with Microsoft Excel.....76

List of Figures

Figure 1. D12 transmitter5

Figure 2. Combustible gas sensor5

Figure 3. Combustible sensor with gas generator5

Figure 4. Wheatstone bridge circuit6

Figure 5. Overall Dimensions-Non Autotest Version (ATI-0587)10

Figure 6. Overall Dimensions- Autotest Version (ATI-0588).....10

Figure 7. Separating the board stack11

Figure 8. Power supply board connections12

Figure 9 Relay Contacts13

Figure 10. ATI A17/B14 Example14

Figure 11. Power Without 4-20mA Signaling Example.....15

Figure 12. 4-20mA Signaling, Single Supply, 3-Wire Example.....16

Figure 13. 4-20mA Signaling, Dual Supply, 4-Wire Example.....17

Figure 14. HART Transmitter, Point-to-Point, 3-Wire Example.....18

Figure 15. HART Transmitter, Multi-drop, 3-Wire Example19

Figure 16. RS485 Modbus Multidrop Example.....20

Figure 17. RS232 Modbus, PC Capture, Printer Example.....21

Figure 18. Remote Sensor Wiring (ATI-0592)22

Figure 19. CPU Board configuration23

Figure 20. Operator interface panel24

Figure 21. Startup review sequence25

Figure 22. Main display26

Figure 23. Standard fault indication26

Figure 24. Variable editing28

Figure 25. Sensor setup page.....29

Figure 26. Data-log warning page.....29

Figure 27. Sensor "more" page.....30

Figure 28. Zero calibration.....33

Figure 29. Zero_Sensor page.....33

Figure 30 Span calibration.....34

Figure 31. Span_Sensor page.....34

Figure 32. Sensor calibration history page.....36

Figure 33. Combustible sensor with auto-test option.....37

Figure 34. Auto-test control page.....38

Figure 35. Auto-test setup page.....38

Figure 36. Auto-test sequence 41

Figure 37. Default alarm relationships for combustible gas sensors. 42

Figure 38. Manual alarm reset 42

Figure 39. Alarm setup pages (example)..... 43

Figure 40. Rising alarm (Active=ABOVE_SP, Reset=AUTO) 46

Figure 41. Falling alarm (Active=BELOW_SP, Reset=AUTO) 46

Figure 42. Fault alarm (Main Display) 47

Figure 43. Fault page..... 47

Figure 44 Alarm relay schematic..... 50

Figure 45. Relay setup page (example)..... 51

Figure 46. Relay test page example 51

Figure 47. Inhibiting alarms from the Main Display..... 52

Figure 48. Alarm inhibit setup page..... 52

Figure 49. Current loop output plot..... 53

Figure 50. 4-20mA setup page..... 53

Figure 51. 4-20mA control page..... 54

Figure 52. Loop adjustment pages..... 54

Figure 53. Data log access page..... 55

Figure 54. Data log setup page..... 55

Figure 55. Data log graphic report page 56

Figure 56. Data log tabular report page..... 56

Figure 57. Data-log printout..... 57

Figure 58. System access page 59

Figure 59. Clock setup page 59

Figure 60. Security control page 60

Figure 61. Activating security 60

Figure 62. Deactivating security 61

Figure 63. Changing the password..... 61

Figure 64. Communication setup page..... 62

Figure 65. Hart setup pages..... 63

Figure 66. Hart a) Find-me and b) Device found pages 64

Figure 67. Modbus setup page..... 65

Figure 68. Transmitter version page..... 65

INTRODUCTION

COMPONENTS

D12 LEL Transmitter

The D12 LEL Transmitter is used to monitor for gas leaks near storage cylinders, process piping, or gas feed equipment in virtually any type of industrial plant environment. Enclosed in an explosion proof housing, it is rated for use in hazardous locations (see specifications). The transmitter features a combustible gas sensor, a non-intrusive, four button interface with back-lighted graphics, three level alarms with three (optional) alarm relays, high-resolution 4-20mA current loop output, real-time clock, data-logger, and optional HART™ or Modbus™ communication interface. In addition, the sensor may be ordered with an optional gas generator for automatic, timed testing of the sensor.

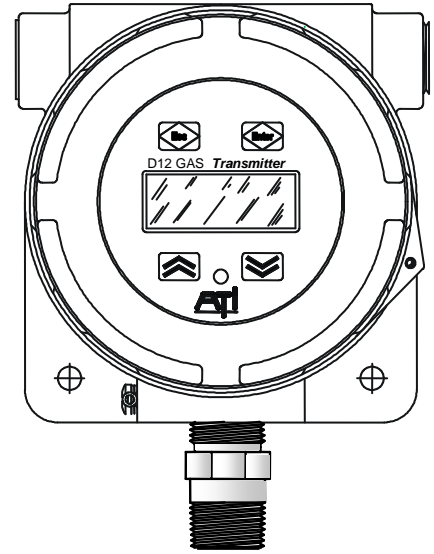
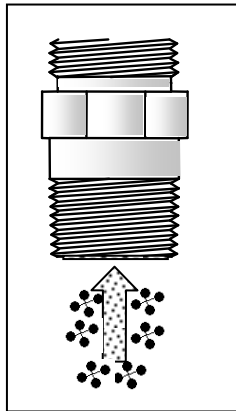

Figure 1. D12 transmitter

The Combustible Gas Sensor

The sensor components are housed in an explosion proof, stainless steel body that is threaded into the base of the transmitter (or remote housing, if ordered). A porous, stainless steel flame arrestor is welded to the exposed end to permit gas entry and to prevent possible ignition of a combustible atmosphere. Threads are cut around the exposed end to accommodate accessories, such as rain shields, and calibration adapters.



Active Element

The sensor's active element is a catalytic bead, which generates heat by oxidizing combustible gas on its surface. This "self-heating" raises the element's temperature and increases the internal resistance, in proportion to the gas concentration.

Reference Element

The reference element is similar to the catalytic bead, but it is inert to combustible gas and acts as a reference to air temperature, and other ambient conditions.

Figure 2. Combustible gas sensor

Auto-test Option

When the Auto-test option is ordered for the combustible sensor, the components are housed in a sensor body that includes a gas generator cell. At a programmed interval and time-of-day, a small current is passed through the cell to liberate a combustible gas. As the volume of gas increases, it fills the cell cavity and travels up a short column that empties onto the face of the sensor. The current is turned off when the transmitter reading rises by a prescribed amount. If the sensor fails to respond, the transmitter (optionally) activates the fault alarm.

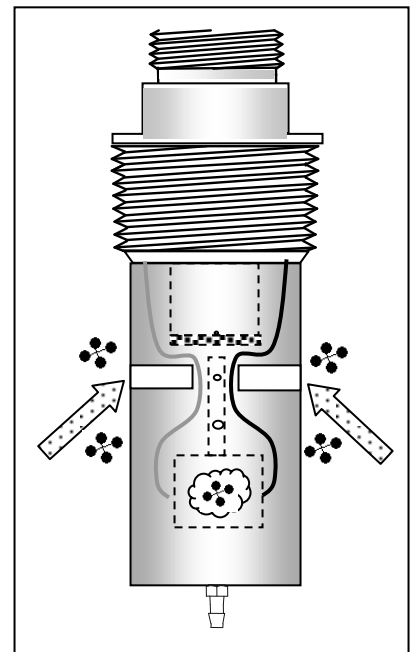

Figure 3. Combustible sensor with gas generator

The sensor elements are combined to form a Wheatstone bridge, as shown in

Figure 4. Gas concentration is computed in proportion to the voltage developed across the bridge, which is read by transmitter's CPU. The CPU linearizes the bridge voltage into a gas concentration reading, and displays it in units of %LEL.

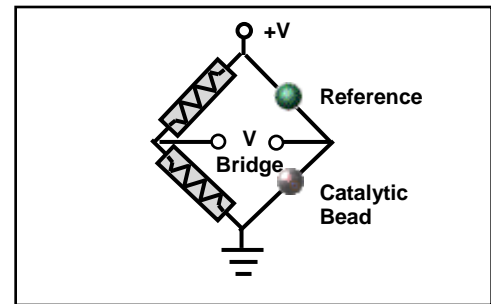

Figure 4. Wheatstone bridge circuit

Gas Mixtures

Rarely are pure gases required for calibration. Instead, gas mixtures are compressed into cylinders and purchased as calibration gas sources. Mixtures are formed by combining a volume of component gas with a volume of balance (or background) gas, and expressed as a ratio or percentage. For example, a mixture containing 0.025 cubic feet of Methane, and 0.975 cubic feet of air would form a 2.5% volumetric mixture of Methane in air:

$$2.5\% = 0.025 / (0.025+0.975) * 100$$

The resulting mixture might be labeled as, “0.025Vol Methane/Bal. Air”, or “2.5%Vol Methane/Bal. Air”, or “50%LEL Methane/Bal Air” (%LEL units are described below). Throughout this manual, air is assumed to be the balance gas, allowing labels like the above to be shortened to “2.5%Vol Methane”, and “1.1%Vol Propane”, etc. Also note that air is usually a mixture of 20.9% Oxygen/Bal. Nitrogen.

LEL, UEL

Combustible gases become explosive when mixed with air at a concentration known as the LEL (Lower Explosive Limit). As more gas is mixed with air, the concentration rises, and remains explosive, until it reaches the UEL (Upper Explosive Limit). Above the UEL, the concentration is considered non-explosive.

The LEL and UEL vary from gas to gas. For example, the LEL of Methane is 5% Vol, while the LEL of Propane is only 2.2% Vol. Likewise, the UEL of Methane is 15% Vol, compared to only 10% Vol for Propane.

%LEL

By default, the transmitter reports combustible gas concentrations as a percentage of the LEL of Methane, or %LEL Methane. Since Methane has an LEL of 5.0% Vol, a 2.5% Vol of Methane is reported as 50%LEL:

$$50\%LEL = 2.5\%Vol / 5.0\%Vol * 100$$

A reading at or above 100%LEL indicates a dangerous, explosive environment exists at the transmitter. Every effort to evacuate personnel and prevent ignition should be taken.

OTM Gases (Other Than Methane)

Unless otherwise noted, the combustible gas sensor is calibrated for Methane. Since the sensor cannot distinguish between different gases, exposure to any other combustible gas will result in erroneous readings, and may present a dangerous condition. This condition may be corrected by recalibrating the sensor's scale, or “span”. See Spanning for OTM Gases (Other Than Methane).



Multiple Gas Safety

Due to differences in LEL and oxidation rates between gases, it is usually best to avoid situations where the sensor may be exposed to more than one combustible gas at the same time. In situations where it cannot be avoided, the sensor should be calibrated to provide the highest margin of safety. See Spanning for Safety.

Oxygen is Essential

Oxygen is essential for the sensor to function. As mentioned above, the catalytic bead oxidizes, or burns, a very small amount of the gas it is intended to measure. Therefore, the sensor must not be used in oxygen-depleted environments. Furthermore, higher concentrations of gas imply lower concentrations of oxygen, so the sensor must not be used to monitor concentrations that might exceed the LEL of the gas.

	<p>The sensor <u>must not</u> be used in oxygen-depleted environments.</p> <p>The sensor <u>must not</u> be used to monitor concentrations of gas that exceed the LEL.</p>	
--	--	--

Gas Flooding

A gas leak in a confined space may eventually decrease the transmitter reading as oxygen is displaced, resulting in an undetectable, explosive condition. For this reason, the transmitter latches the reading at 100%LEL, and holds it until manually reset. Relay RL3 is assigned to the high alarm, labeled Alarm, which is set to activate at 50%LEL and remain active until manually reset. Alarms derived from the current loop output should also require manual reset, and be configured to activate at or below 60%LEL.

	<p>Do not enter any area reporting an alarm until confirming independently it is safe to do so.</p>	
--	--	--

Compounds to Avoid

Silicon

Catalytic bead sensors are adversely affected by silicon, such as might be present in lubricants and sealants. High concentrations of silicon vapor can cause complete loss of sensitivity in as little as a few hours. These sensors should not be used where silicon vapors are normally present and sensors should be protected from these vapors if such compounds are in use temporarily.

Hydrogen Sulfide

Hydrogen sulfide will reduce sensitivity after a few weeks of exposure, but will usually level out. The effects may be compensated for by spanning the sensor (see Span Calibration).

Lead

While not commonly encountered, exposure to lead compounds may result in a total loss of sensitivity.

	<p>Avoid exposing the sensor to Silicon-based compounds, Hydrogen Sulfide, and Lead compounds.</p>	
--	---	--



SPECIFICATIONS

Table 1. Specifications

Gas Type	Combustible gas such as Methane, Propane, Butane, plus many more, including Ammonia and Hydrogen
Sensor Type	Catalytic bead for combustible gas, 316 stainless steel housing
Range	50 – 100% LEL
Response Time	T90 in 10 seconds
Accuracy	±1% LEL
Repeatability	±1% (Electronic)
Linearity	±0.5% (Electronic)
Zero Drift	Less than 2% full scale per month
Span Drift	Dependent on operating environment but generally less than 3% per month
Analog Output	4-20 mA, 675 ohms max. at 24 VDC
Serial Interface	HART® (1200 baud Bell 202 modem interface) Modbus ® (1200-9600, 14.4k, 28.8k, RS232 or RS485) ASCII datalogger output
Power	12 – 30 VDC, 250 mA maximum
Alarm Relays	Three SPST, 5 A @ 250 VAC resistive
Relay Coil	Programmable either normally energized or normally de-energized.
Enclosure	Explosion-proof, Class 1, Div. 1, Groups B, C, & D.
Auto-Test	Optional
Display	Graphics LCD, 96w x 32h, back-lighted
Controls	Four button, non-intrusive (magnetic switches); remote alarm reset input
Operating Temp	-40° to +75° C
Weight	4 Lbs. (1.8 Kg.)
Remote Sensor	Optional, 25ft Max.

INSTALLATION

MECHANICAL MOUNTING

Transmitter

Figure 5 shows the dimensions of the transmitter enclosure and the location and size of the electrical conduit connection. In locations classified as hazardous

(explosive), the transmitter housing must be earth grounded, and an explosion-proof seal must be installed as required by the local electrical code. The conduit or cable gland entry into the enclosure must be sealed. If conduit is used, it must also be sealed internally at the housing entry. This is required to prevent condensation from draining into the enclosure.

	 HAZARDOUS LOCATIONS	
<p>Connect housing to earth ground. Use explosion proof conduit, and seal it inside and out. Follow national, state, and local, electrical codes.</p>		

**Seal conduit inside and out to keep out water.
Follow national, state, and local, electrical codes.**

Secure the transmitter to a wall or flat surface through two mounting holes in the enclosure, as shown in Figure 5 and Figure 6. If appropriate fasteners are used, the transmitter may be supported by conduit alone.

The transmitter should be mounted with the sensor facing down. Transmitters are shipped with a protective plastic cap over the sensor that should be left in place during installation, and removed before placing the transmitter in service (leave the cap installed whenever painting around the transmitter).



Series D12 LEL Gas Transmitter with Catalytic Bead Sensor

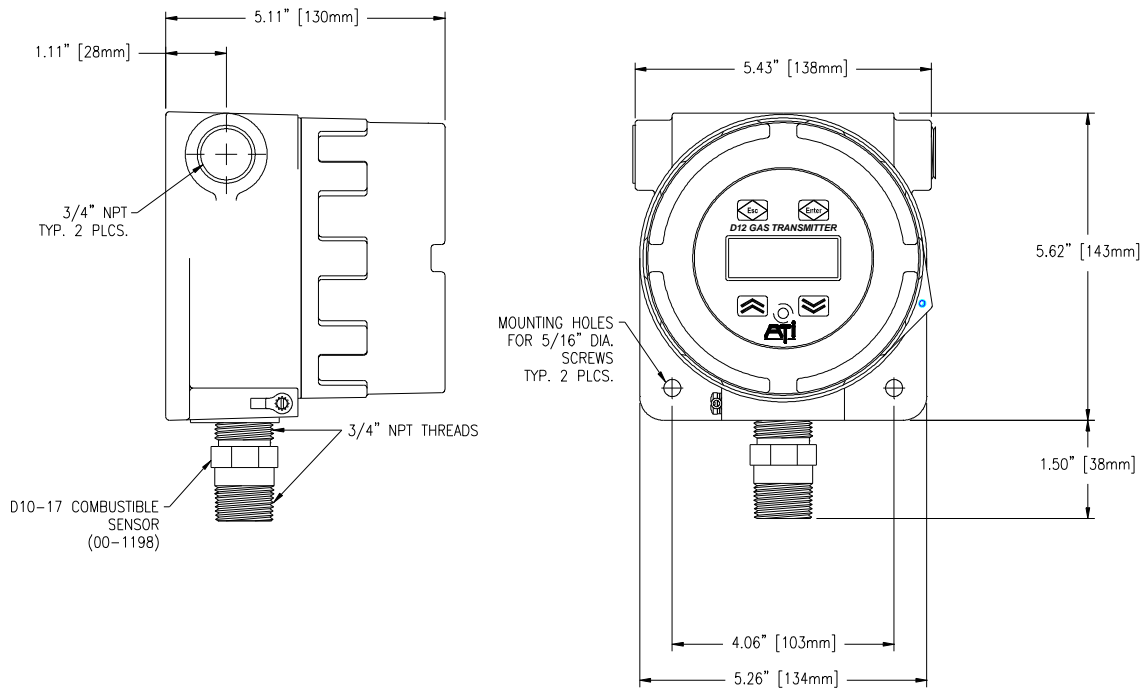

Figure 5. Overall Dimensions-Non Autotest Version (ATI-0587)

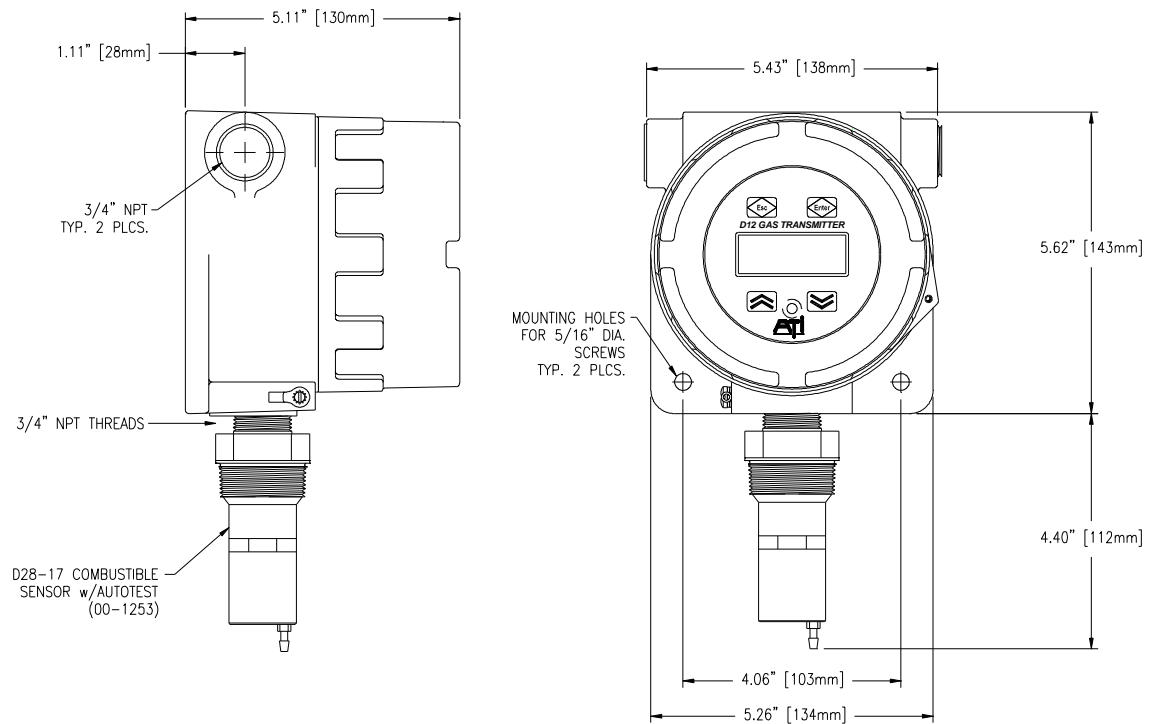

Figure 6. Overall Dimensions- Autotest Version (ATI-0588)



ELECTRICAL CONNECTIONS

The Stack

The transmitter consists of three circuit boards, known collectively as the “stack”. From top to bottom, they are the, Display, CPU, and Power Supply. The top two boards, Display and CPU, are fastened together with metal standoffs, and plug into the Power Supply board, which is fastened to the lower housing with similar metal standoffs. Since most external wiring connections are made to terminals on the Power Supply board, it will be necessary to remove the top two boards.

Grasp the outer edge of the metal faceplate covering the Display board and gently rock it side to side, while pulling it up and away from the housing. Once the top two boards come free, lift them out and disconnect the sensor ribbon cable (note: this connector is keyed for ease of reconnecting later).

Please be aware of the hidden ribbon cable that connects the top two boards to the lower board. This cable is long enough to permit the boards to come free from the housing, but no further.

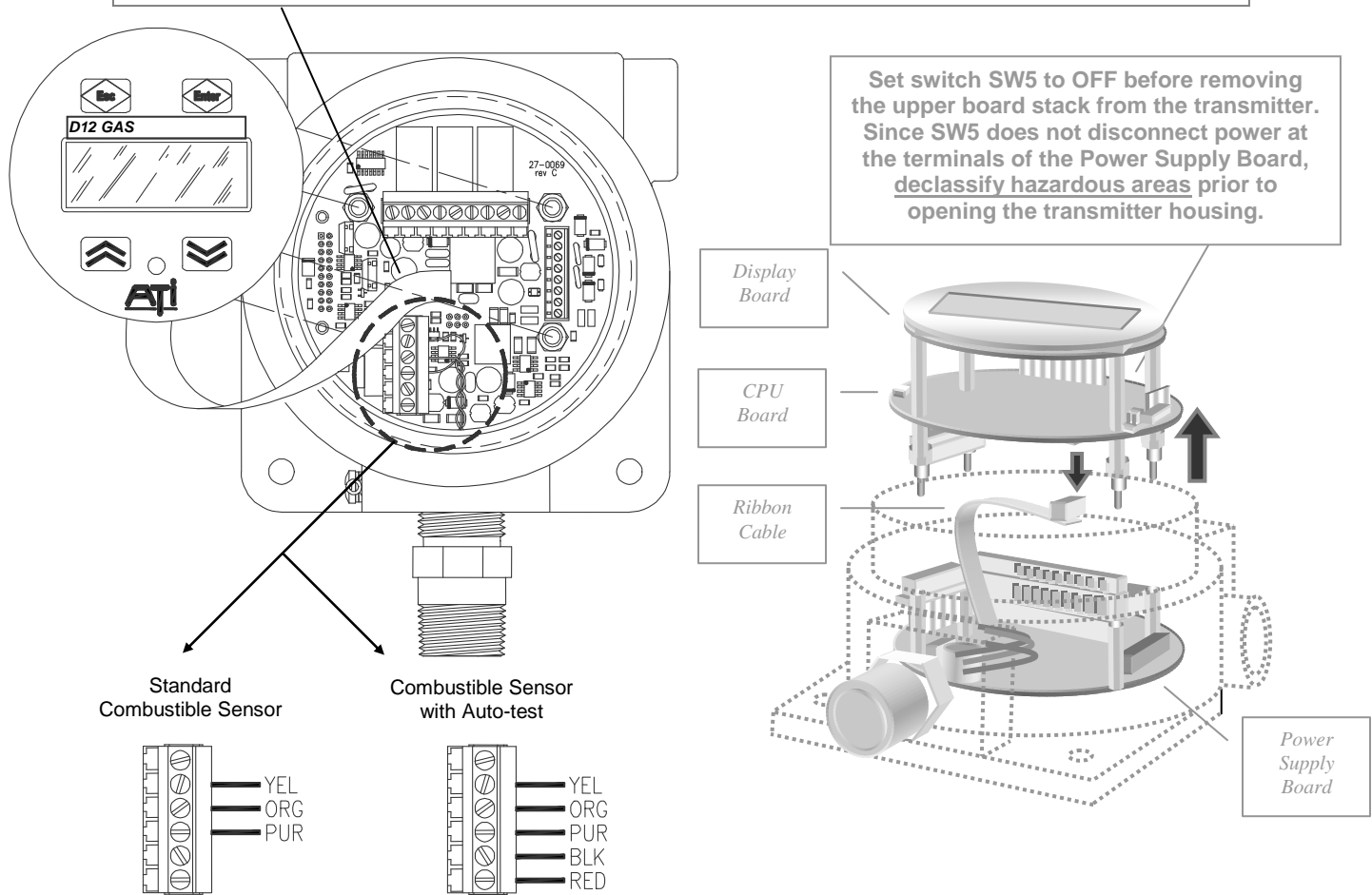

Figure 7. Separating the board stack

External Power Supply

The transmitter requires a regulated DC supply, operating between 12 and 30 VDC. Transmitters ordered with relays will require a maximum current of 250mA, worst case (all relays energized). Power supplies for operating multiple units should be sized for twice the calculated load to allow for start-up (inrush) current.



Power Supply Board

Electrical connections are made to terminal blocks TB1 and TB2. The 4-20mA current loop, optional digital communications, and remote alarm reset, are connected at TB1. Connections to the three optional relays are made at TB2. It is recommended to power the transmitter, and all controls and indicators, from separate, uninterruptable supplies.

Note: This version of the transmitter cannot operate on loop power alone.

The transmitter requires primary power in the range of 12 to 30 VDC applied to pins 7 and 8 on TB1. Current loop operation requires power in the same range on pin 5 (mA+), from which the transmitter sources a positive, 4-20mA output on pin 6 (mA-).

IMPORTANT

The loop supply voltage on pin 5 must not exceed the primary supply voltage on pin 8.

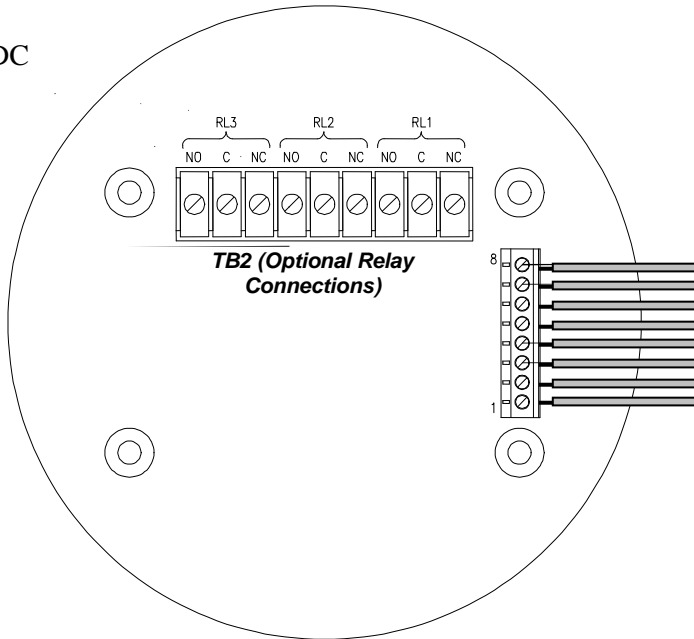

Figure 8. Power supply board connections

In 3-wire mode, the transmitter requires a maximum of 250 mA, with all relays active. Power supplies operating multiple units should be sized for twice the calculated current requirement to allow for inrush current during startup.

The housing has limited space for wire. Use the smallest gauge wire available that is compatible with electrical code and current requirements. When powering a group of transmitters in 3-wire mode from the same power supply, 12 AWG wire is recommended for long runs, with smaller (higher gauge) wire drops to each transmitter.

Internal relays are best used as pilot relays if heavy load switching is required. Use suitable arc suppression devices across loads switched through internal relays.

The transmitter housing may be grounded through explosion proof conduit. In the absence of such conduit, use a suitable grounding strap to bond the transmitter's housing to earth ground.

Always follow wiring practices governed by local, state, and national electrical codes.

Relay Contacts

Note: the behavior described below is determined by the default relay settings, which may be reprogrammed through the operator or communication interface.

By default, RL1 is de-energized until the gas concentration reaches the Warning level, and is then energized until the alarm is cleared, or power fails. Likewise, RL2 is de-energized until the gas concentration reaches the Alarm level, and is then energized until the alarm is cleared, or power fails. In contrast, RL3 is energized until a Fault condition is detected, or power fails, and is then de-energized until the condition is cleared.

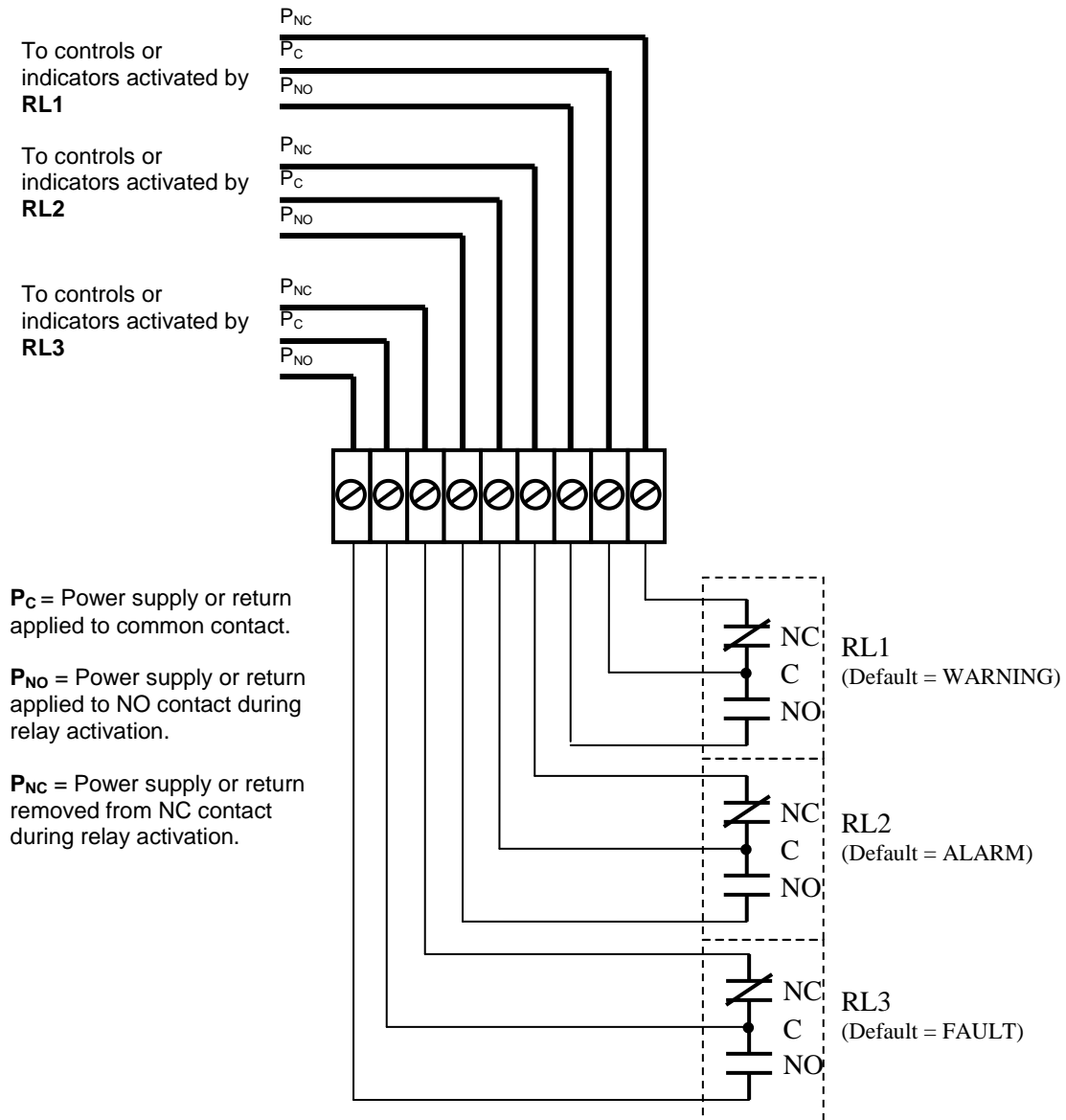

Figure 9 Relay Contacts



Wiring Examples

ATI A17/B14, 3-Wire Mode

A single ATI A17 Power Supply may be used to power one ATI B14 Receiver with single D12-17 transmitter, as shown below.

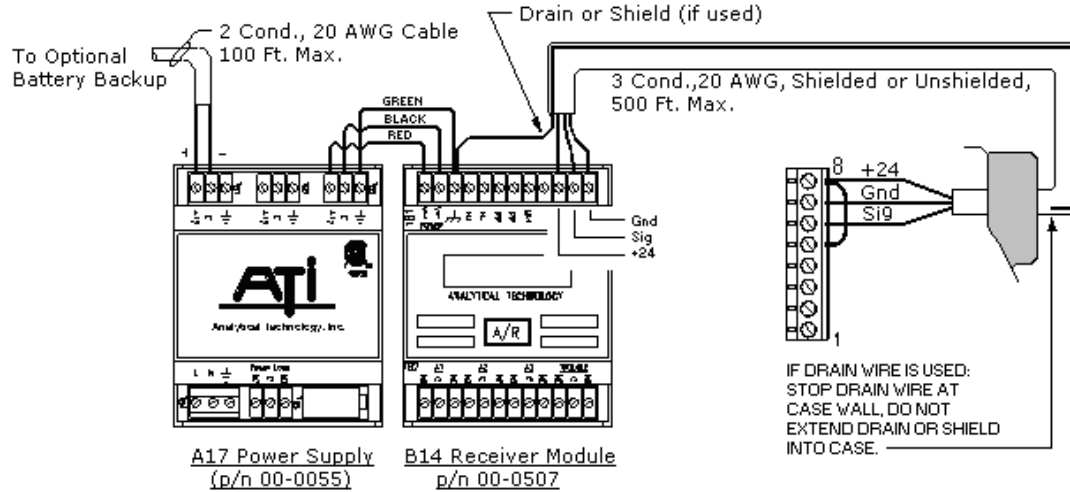

(see B14 Monitor O&M Manual)

Figure 10. ATI A17/B14 Example



Power Without 4-20mA Signaling

Power without 4-20mA signaling is not common practice, except when signaling digitally over HART multidrop and Modbus connections. There are several examples of those in the pages that follow.

When 4-20mA signaling is not used, the transmitter may be powered from TB1-5,6,7,and 8, which are connected directly to the supply (note 1). Multiple transmitters may be powered this way, as shown. Size each power supply according to the number of transmitters, the current demand of each (see specifications), and the wire resistance. The wire resistance must not be allowed to drop the primary supply voltage below 12V at the primary supply terminals of any transmitter. Hint: If possible, use 12-14 AWG wire on primary supply connections, keep the number of transmitters low, and verify the voltage on the on the transmitter furthest from the supply.

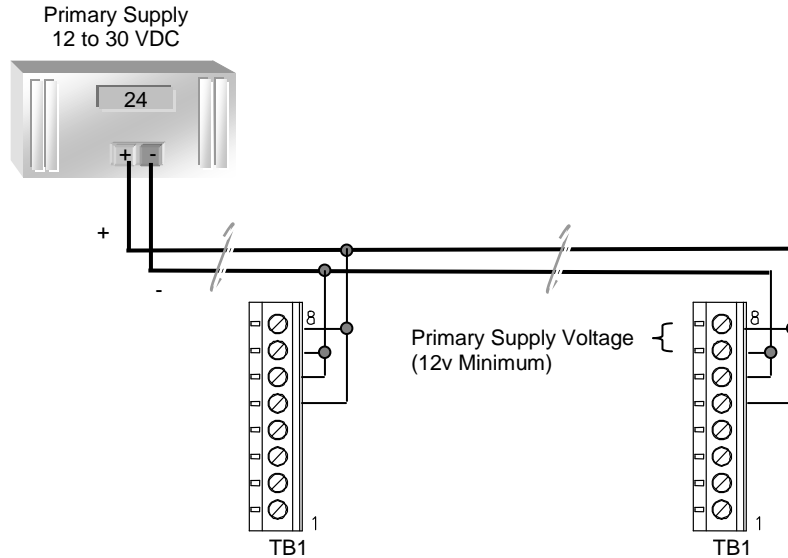

Figure 11. Power Without 4-20mA Signaling Example

Notes

1. Power without 4-20mA signaling is not common practice, except for HART multidrop or Modbus connections that use digital signaling (not shown), providing a local alarm, or both. Power shown above is sufficient for Modbus connections, relays, and LCD backlight operation.

4-20mA Signaling, Dual Supply, 4-Wire Mode

To reduce the power requirement of a single current loop supply, the transmitter may be powered from both a primary and loop supply, providing the following conditions are met.

1. Supply grounds are directly connected to minimize ground loops, and,
2. The Primary Supply Voltage must not drop below the Loop Supply Voltage, as measured at instrument terminals.

Size each power supply according to the number of transmitters, the current demand of each (see specifications), and the wire resistance. The wire resistance must not be allowed to drop the Primary Supply Voltage below the Loop Supply Voltage, as measured at the terminals of any transmitter. Hint: select a Primary Supply with a higher voltage output than the Loop Supply, and use 12-14 AWG wire, if possible. Keep the number of transmitters supplied by the Primary Supply low, and verify the voltages at the terminals of the transmitter furthest from the Primary Supply.

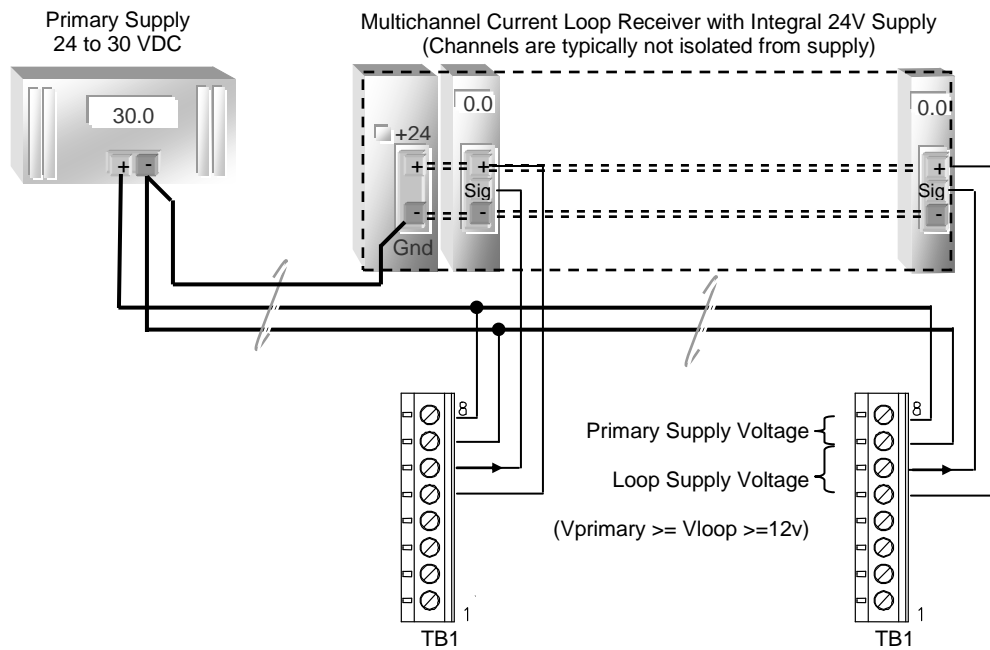

<p>IMPORTANT</p> <p>Primary Supply Voltage must not drop below Loop Supply Voltage at terminals of any transmitter.</p> <p>Hint: Use 12 AWG wire on Primary supply connections to minimize voltage drops.</p>	<ol style="list-style-type: none"> 1 Select a Primary Supply with a higher voltage output, and, 2 Connect supply commons to minimize ground loops and voltage drops that might reduce the Primary Supply Voltage below the Loop Supply Voltage, at transmitter.
--	---

Figure 13. 4-20mA Signaling, Dual Supply, 4-Wire Example

HART Transmitter, Point-to-Point, 3-Wire (Active Source)

The HART “Point-to-Point” connection permits the transmitter to communicate digitally, while retaining the functionality of its 4-20mA current loop. Setting the transmitter’s polling address to 0 permits the current loop to function normally. According to HART specifications, the current loop must be terminated with a load resistor between 230 and 1100 ohms; however, transmitter specifications restrict the maximum analog output resistance to a lower value (see Specifications). The term, “active source”, refers to a transmitter that is not loop powered, and sources current from power applied to it on separate terminals. Size the power supply according to the number of transmitters, the current demand of each transmitter (see specifications), and wire resistance. Wire resistance must not be allowed to drop the Primary Supply Voltage below 12V at the terminals of any transmitter. Hint: use at least 14 AWG wire on supply connections (shown in bold).

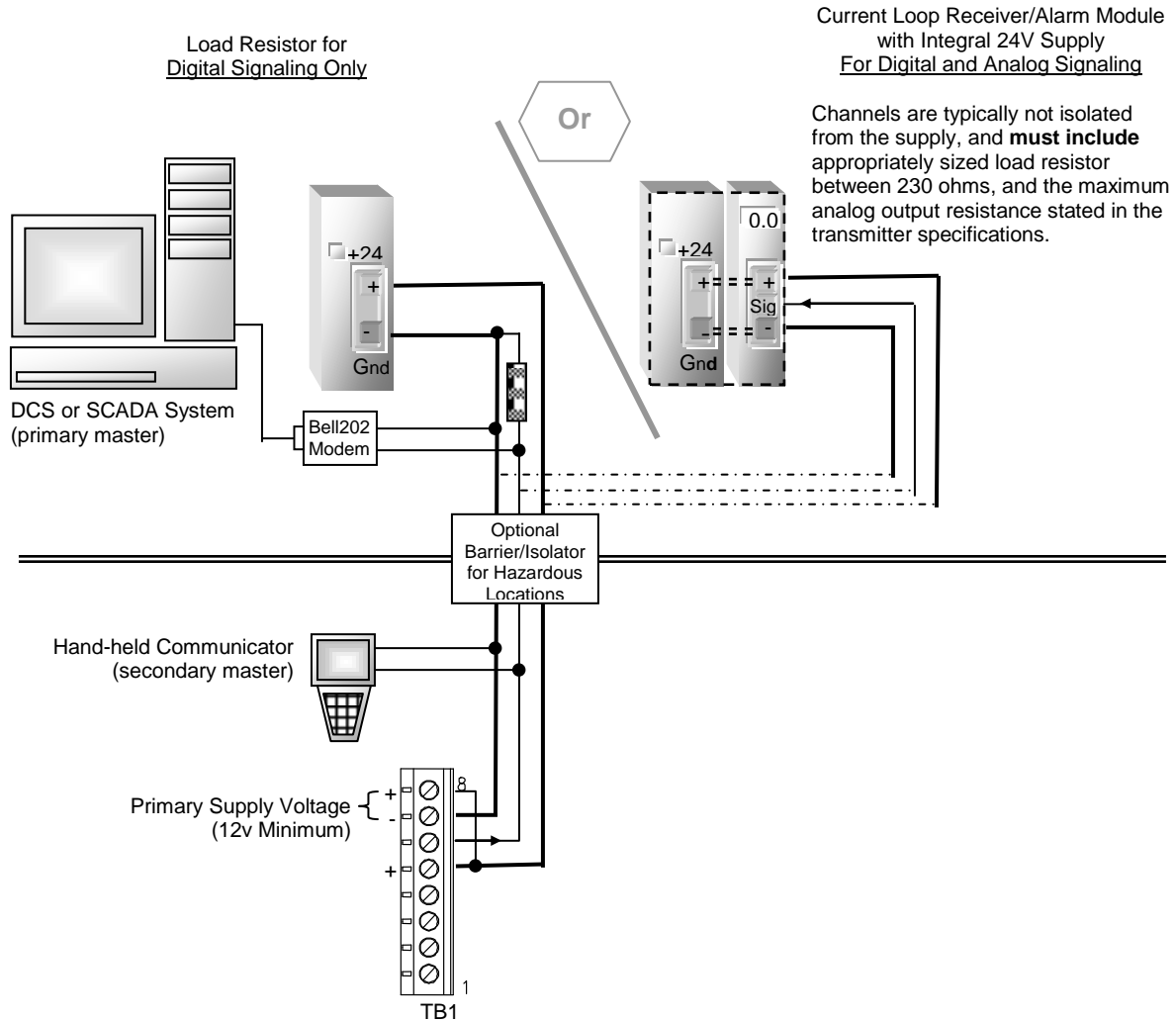

Figure 14. HART Transmitter, Point-to-Point, 3-Wire Example

HART Transmitter, Multi-drop, 3-Wire (Active Source)

The HART “Multi-drop” connection permits up to 15 transmitters to communicate digitally on the same bus, but at the cost of analog current signaling. Setting the transmitter’s polling address from 1 to 15 fixes the current loop output at 4mA. According to HART specifications, the current loop must be terminated with a load resistor between 230 and 1100 ohms; however, transmitter specifications restrict the maximum analog output resistance to a lower value (see Specifications). The term, “active source”, refers to a transmitter that is not loop powered, and sources current from power applied to it on separate terminals. Size the power supply according to the number of transmitters, the current demand of each transmitter (see specifications), and wire resistance. Wire resistance must not be allowed to drop the Primary Supply Voltage below 12V at the terminals of any transmitter. Hint: use at least 14 AWG wire on supply connections (shown in bold).

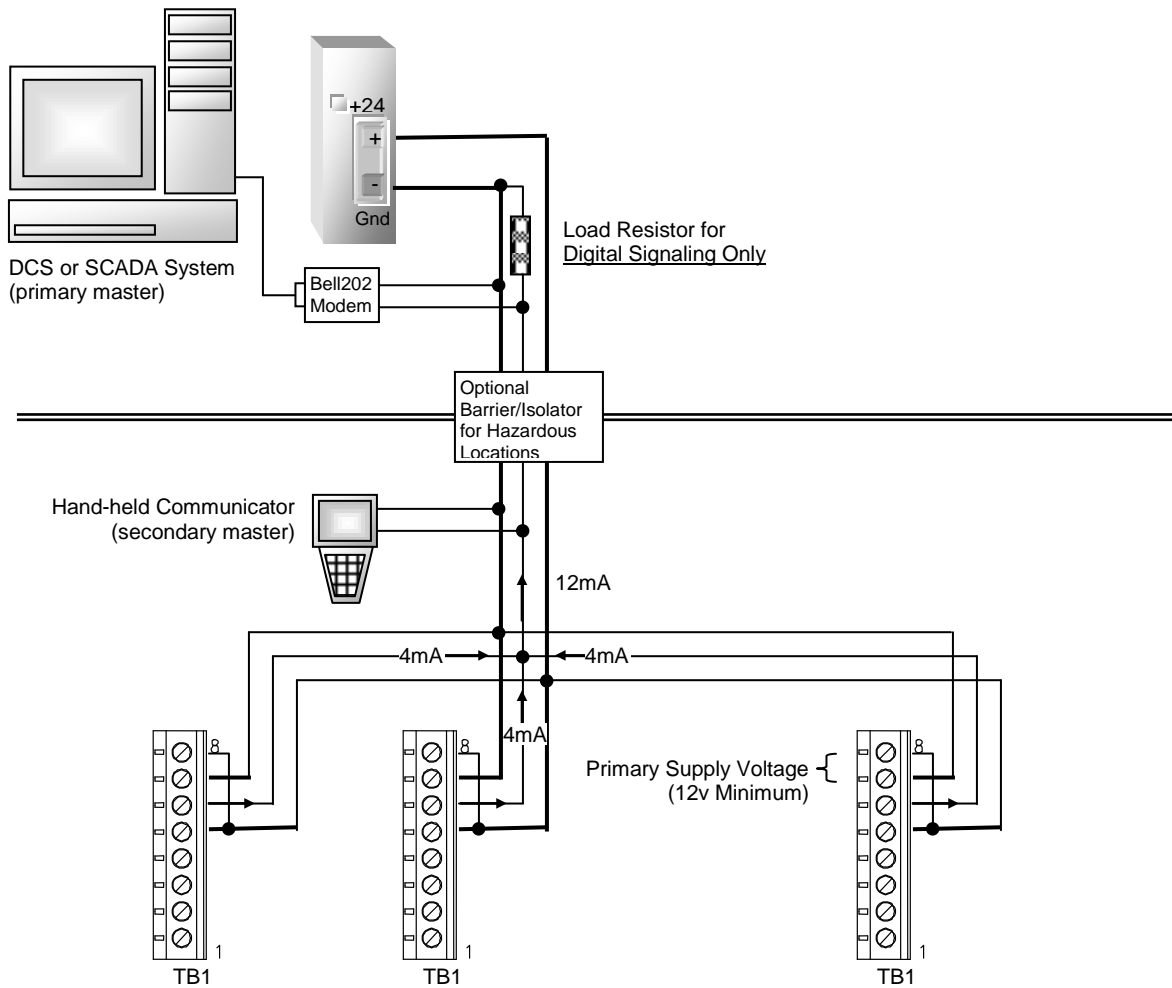

Figure 15. HART Transmitter, Multi-drop, 3-Wire Example



RS485 Modbus Multidrop

RS485 operation requires the transmitter to be wired in 3- or 4- wire mode. In addition, the RS485 or RS485 UNTERMINATED COM jumper must be installed at JP4 on the CPU. Modbus permits up to 247 devices to communicate digitally on the same bus; however, RS485 limits this to 32. Refer to the **Modbus Interface Manual** for details on Modbus connections and implementation.

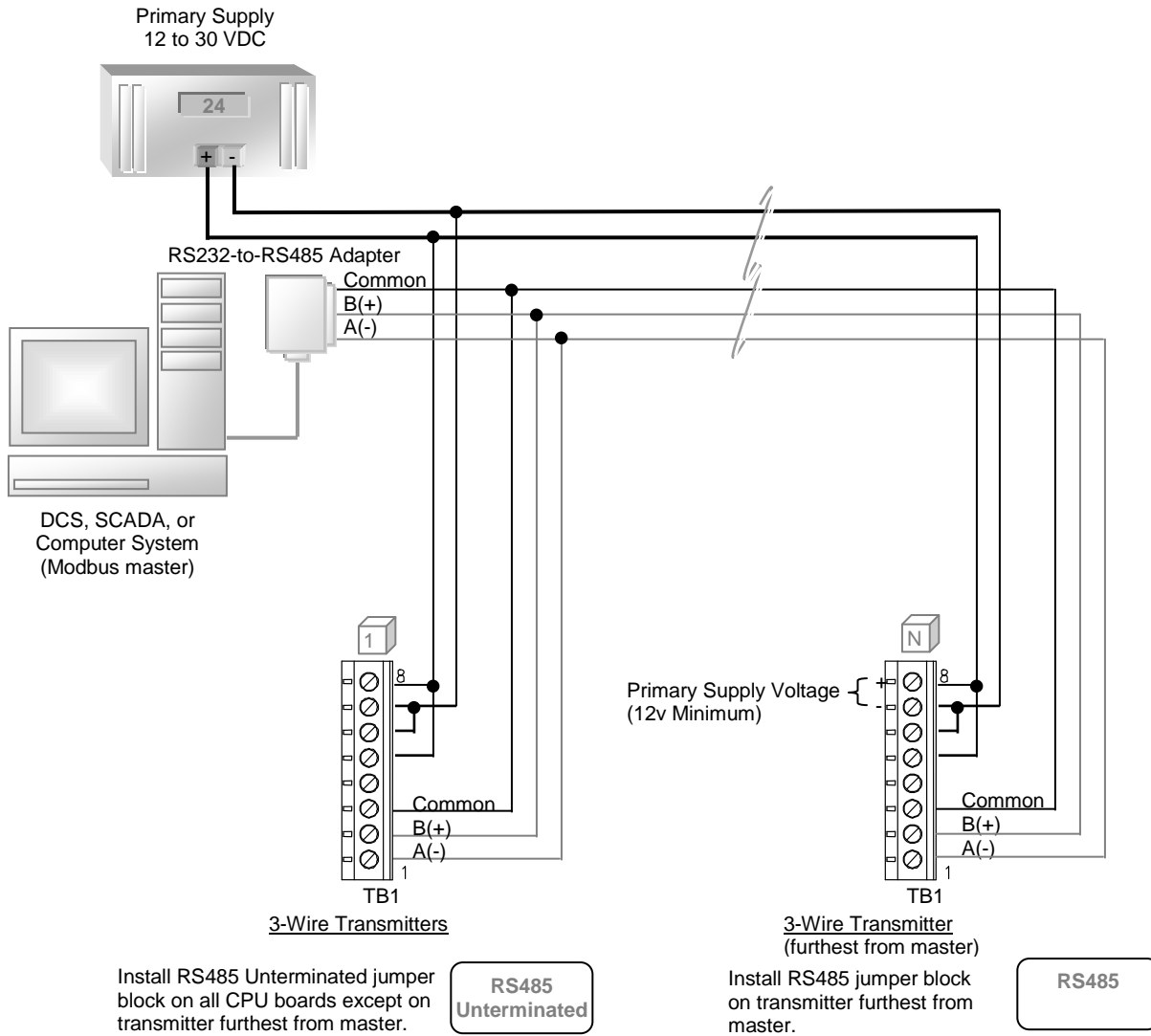

Figure 16. RS485 Modbus Multidrop Example



RS232 Modbus, PC Capture, or Printer

RS232 operation requires the transmitter to be wired in 3- or 4- wire mode. In addition, the RS232 COM jumper must be installed at JP4 on the CPU board. The RS232 connection may be used for a Modbus connection, capturing the data log output using a PC, or printing the data log output to an Epson compatible printer. Refer to the **Modbus Interface Manual** for details on Modbus connections and implementation, and to Appendix A. on page 68 for details on outputting data log reports.

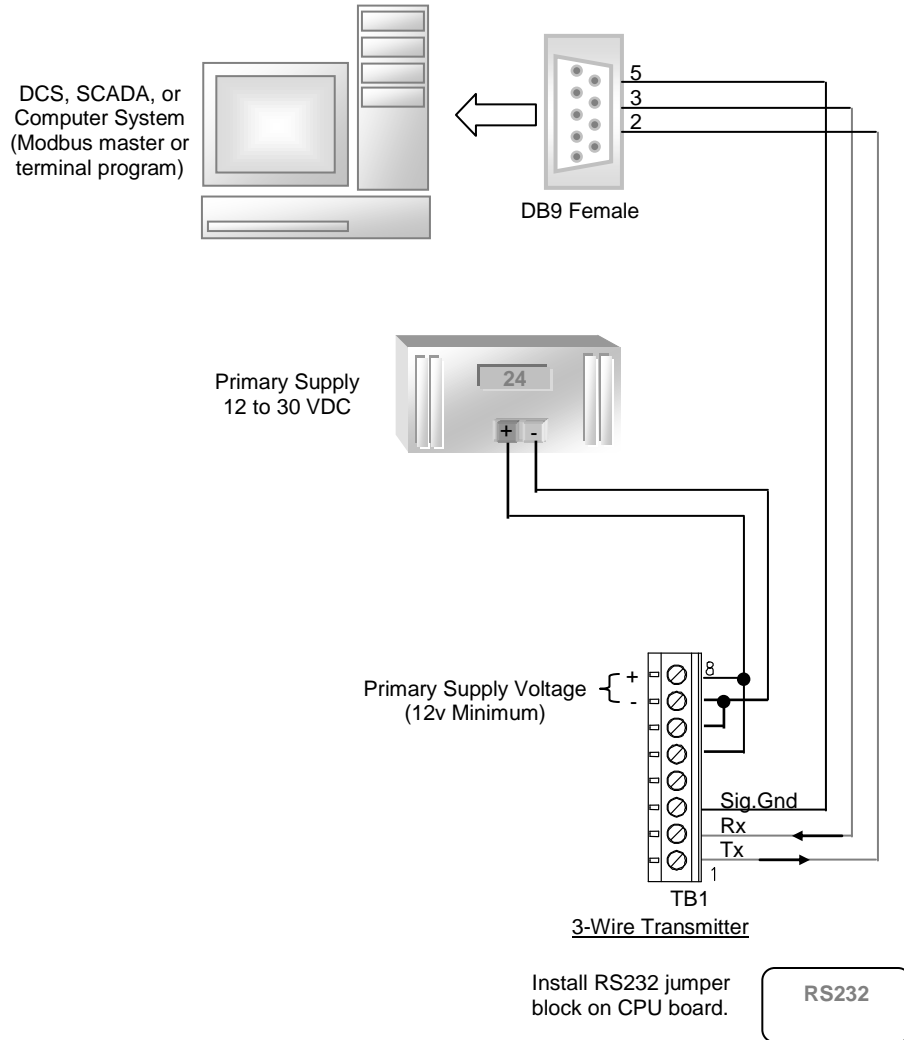

Figure 17. RS232 Modbus, PC Capture, Printer Example

CPU Board Configuration

Install one jumper plug on JP4 as prescribed by communication interface.

If equipped with relays, install the relay option jumper on pins 3-4 of JP1.

Set switch SW5 ON before replacing the housing cover.

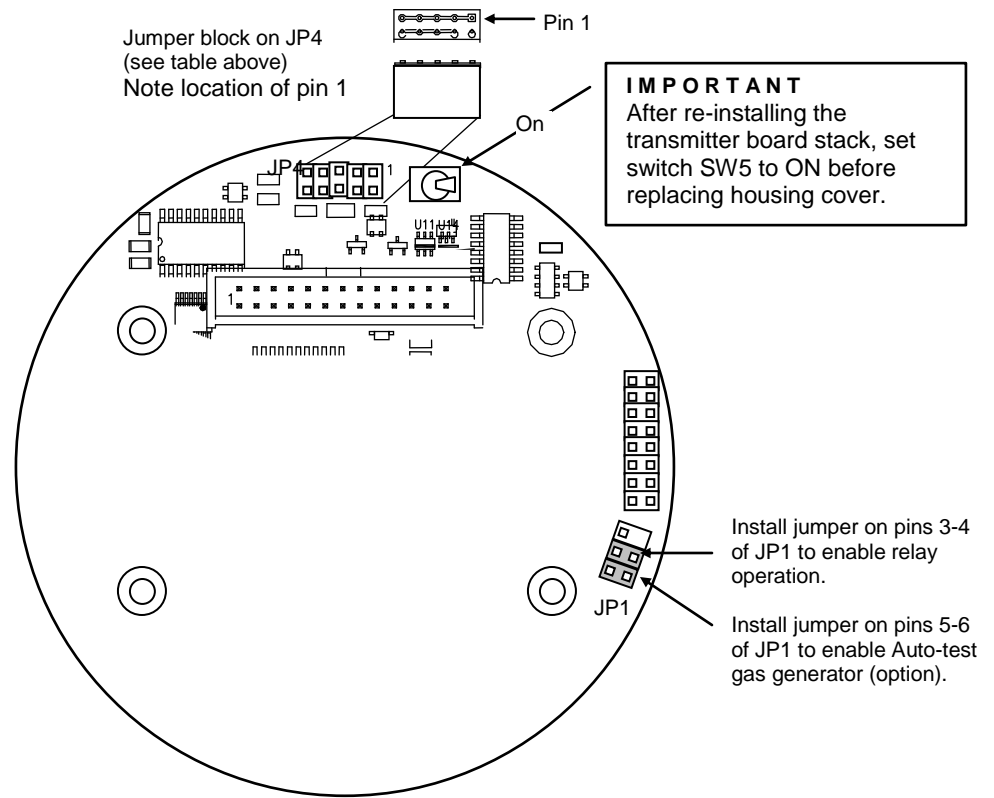

Figure 19. CPU Board configuration

Table 2. Communication option jumpers

Protocol	Interface	Jumper Plug Label	Comments
HART	Bell 202	N/A	No plug required (okay to install any)
Modbus	RS232	"RS232"	Use to connect one transmitter to a master device in a "point-to-point" configuration. See "D12 Modbus Manual" for details.
Modbus	RS485	"RS485"	Use to connect up to 4 transmitters to a master device in a "multi-drop" configuration. Each transmitter connection biases and terminates the transmission line, as shown below. See "D12 Modbus Manual" for details.
Modbus	RS485	"RS485 Unterminated"	Use to connect more than 4 transmitters to a master device in a "multi-drop" configuration. Transmitters are connected without adding bias or termination. Install one (terminating) "RS485" jumper plug on transmitter at furthest end of transmission line. See "D12 Modbus Manual" for details.
ASCII	RS232	"RS232"	Use to connect one transmitter to a printer, or system terminal (see Data logging section).

OPERATION

OPERATOR INTERFACE

Interface Panel

The D12 operator interface is non-intrusive, so you do not have to remove the housing cover to view the display, configure the transmitter, or calibrate the sensor. It features a backlighted*, 96x32 dot LCD display, and four “keys”. The keys are implemented as four magnetic switches, each centered below a graphic icon, and activated when a magnet is held approximately 1/4” above the icon. The transmitter is provided with a powerful, magnetic-screwdriver, designed specifically for activating the switches through the housing’s thick, glass window. Throughout this manual, activating keys in this manner is referred to as, “touching” the keys, even though it is not necessary to make physical contact.

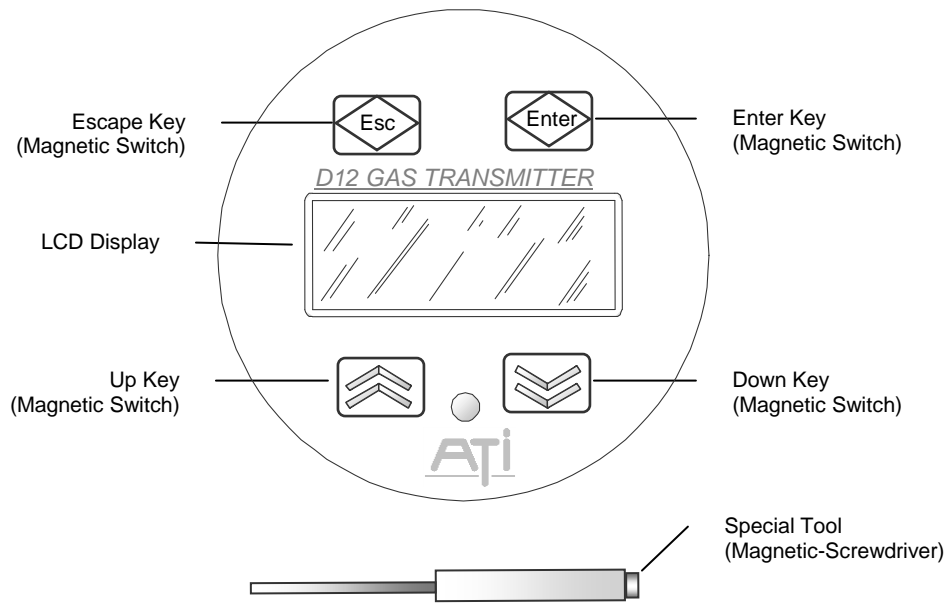

Figure 20. Operator interface panel

The operator interface is organized into pages that consist mostly of text objects representing readings, indicators, variables, functions, and links to other pages. Navigating the pages of objects is simplified through the use of a “point-and-click” interface, using an arrow cursor that may be moved from one object to the next by “touching” the up or down key. While the cursor is “pointing” at an object, touching the magnet to the Enter key is said to “select” the object, and the action performed depends on the type of object. If the object is a function, the Enter key executes the function. If a variable is selected for editing, the Up and Down keys change its value, and the Enter key saves it. Touching the Esc key aborts the edit and restores the previous value. If not executing a function, or editing a variable, touching the Esc key returns to the previous page.

(* back-lighting available in 3- or 4-wire mode, only)



Startup Review Sequence

When the transmitter starts, the display cycles through a series of pages to review the configuration of the transmitter, sensor, and generator. Alarms are inhibited, and the output of the transmitter is held at 4.0 mA. This state is maintained for 5 minutes to provide time for the sensor readings to stabilize.

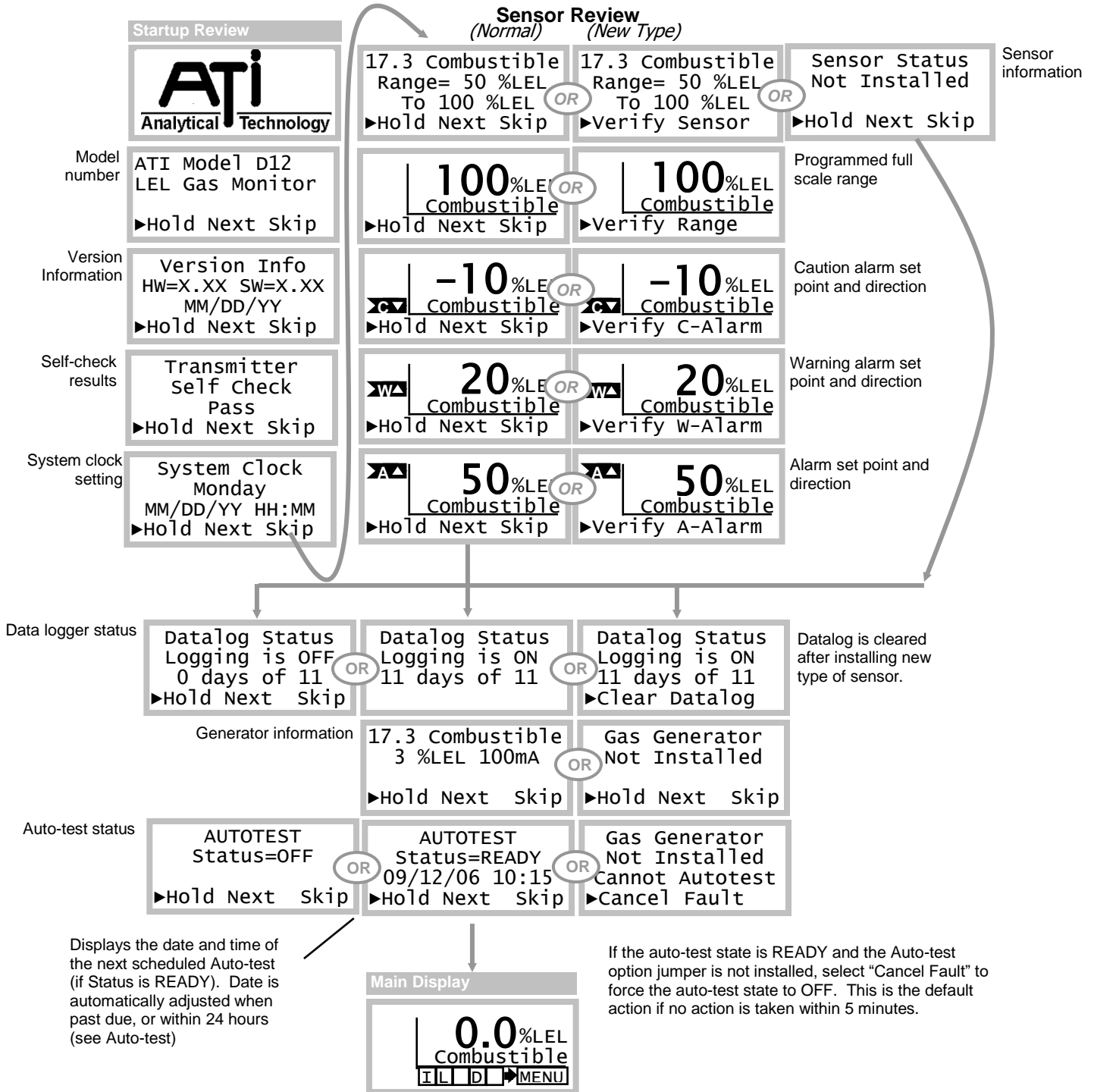

Figure 21. Startup review sequence



Main Display Page

The Main Display Page shows the name and concentration of the target gas, and units of measurement (PPM, PPB, %, etc). Indicators on the left and below show alarm and operating status.

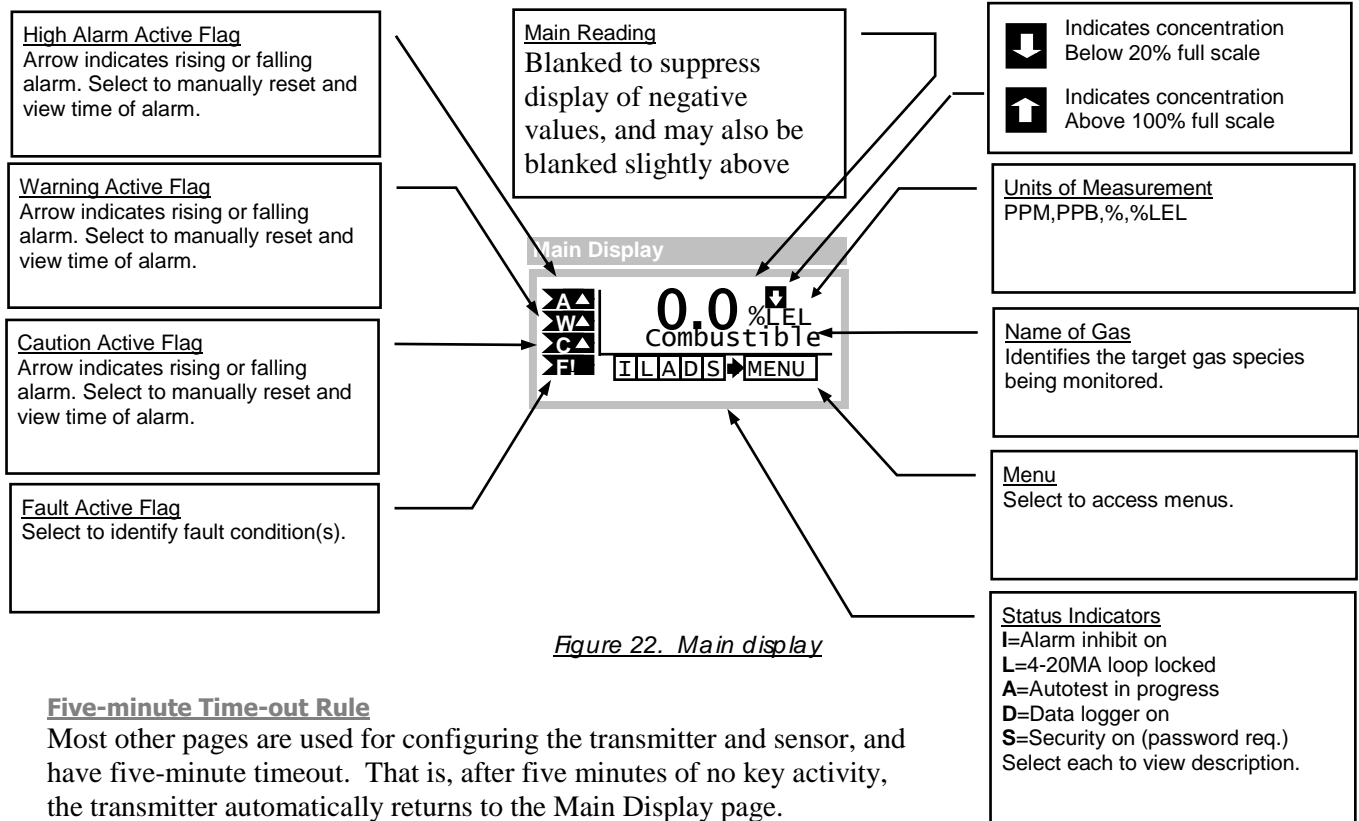
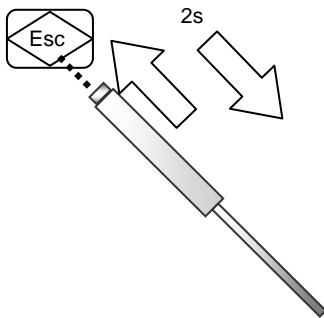

Figure 22. Main display

Five-minute Time-out Rule

Most other pages are used for configuring the transmitter and sensor, and have five-minute timeout. That is, after five minutes of no key activity, the transmitter automatically returns to the Main Display page. Exceptions to this rule include the zero and span calibration pages.



Esc Key Operation (Main Display Page)

Holding the magnet over the ESC key for 2 seconds, then removing, toggles alarm inhibit mode on and off. If the alarm inhibit mode was off, it is turned on for 15 minutes (default value). If alarm inhibit was on, it is turned off immediately. Alarm inhibit mode is on when the “I” status indicator is visible.

Fault Indication (Main Display Page)

Faults are indicated on the Main Display Page as shown in Figure 23.

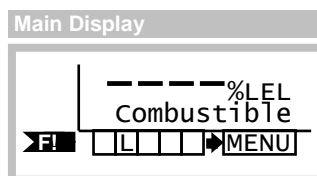
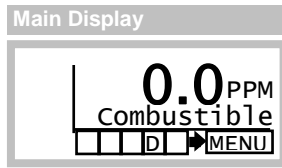

Figure 23. Standard fault indication



Main Reading

The main reading represents the gas concentration value and appears on the Main Display, along with the sensor name, and units of concentration. It is reported on the 4-20mA output¹, and is the PV (Primary Variable) reported on the optional HART™ interface. It also appears at register 40043 (D12_SYS_CONCBL) on the optional Modbus interface.



By default, the main reading is blanked to suppress the display of negative values. That is, the reading is reported as zero if the concentration should dip below zero, which can occur over time as a result of sensor aging. If the concentration falls to -20% of the full-scale range, a fault alarm is generated. Blanking is typically extended slightly above zero, as a means of stabilizing the main reading in the presence of excessive external noise, or other environmental factors (see Sensor Setup Page).

During zero and span calibration, the “un-blanked” gas concentration value is displayed, primarily to assess the amount of positive or negative drift. The “un-blanked” reading is also available on the Modbus interface (request “D12 Transmitter Modbus Interface Manual”, for more information).

¹ The 4-20mA may not match the reading when the “L” status indicator is visible on the Main Display, or when the output is in a physical limit.



Sensors and Generators

The transmitter offers several pages for accessing and configuring the combustible sensor and its optional gas generator. Neither sensors nor generators have local memory; therefore, all settings are stored in the transmitter memory.

Sensor Setup

Sensor Setup Page

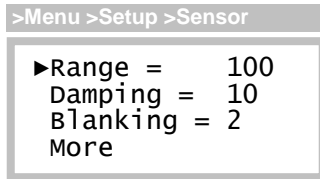

Figure 25. Sensor setup page

Table 3. Sensor variables

Variables	Description
Range	The Range variable sets the 100% full-scale value of the transmitter, which corresponds to the 20mA output value. Changing the range value also changes the Blanking value, which is computed as a fraction of the range. In this version of the transmitter, Range is limited from 50 to 100 %LEL.
Damping	The Damping variable allows minor adjustment of the transmitter’s auto-damping feature, used to stabilize readings. It is a unit-less value from 1 to 100, where a value of 1 corresponds to a T90 ³ response of approximately 20s, and 100 is a T90 of approximately 30s. The default value is 10, resulting in a T90 response of approximately 21s.
Blanking	The Blanking variable is used to force the main reading to zero, whenever the gas concentration is below the programmed value. In this version of the transmitter, Blanking is limited from 0 to 10 % of Range. Note that the transmitter always performs negative blanking, even when Blanking is set to 0. The variable is recomputed when the Range variable changes, so that same fraction of range is maintained. Doubling, or halving the Range variable, doubles or halves the Blanking variable, respectively.
More	More is a link to an additional sensor information page (below).

The data-logger records readings as a fraction of the sensor range. If data logging is turned on (indicated by “D” status indicator on the Main Display), changing the Range variable causes a warning message to appear prior to saving the value. Select “Save” to save the new Range variable, or “Abort” to leave it unchanged.



Figure 26. Data-log warning page

³ T90 is the time required for the transmitter to reach 90% of its final value, after a step change in gas concentration.



Sensor More Page

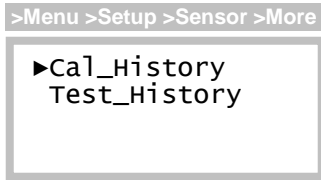

Figure 27. Sensor “more” page

Table 4. Sensor “more” variables

Variables	Description
Cal_History	Cal_History is a link to the Calibration History page (see Sensor Calibration Records).
Test_History	Test_History is a link to the Auto-test History page (see Auto-test History Page)

Bump-Testing

“Bump-testing” refers to a test whereby the sensor is briefly exposed to gas in order to verify the reading moves upscale from zero. It is recommended that it be performed at least once a month, using a small amount of bottled span gas.

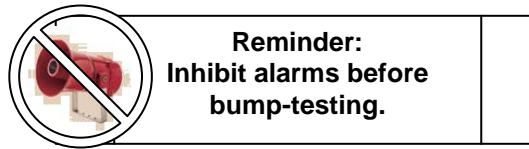

Exposing the sensor to any reactive gas could cause false alarms, and can be avoided by temporarily inhibiting them. The most convenient method for doing so is from the Main Display, using the Esc key. This also allows you to view the transmitter reading to verify the sensor’s response.

To quickly inhibit alarms...

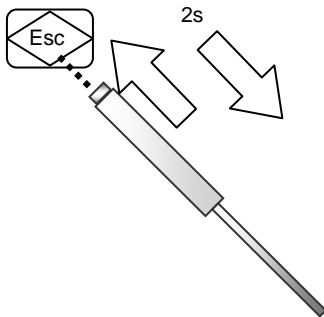

Hold the magnet over the ESC key for 2 seconds, and remove it. This will toggle the alarm inhibit mode on for 15 minutes (default value), hold the current loop at 4mA, and cause the “I” and “L” status indicators to appear. Repeat the procedure when finished with the bump-test, and verify the flags disappear. See “Inhibiting Alarms” for more details.



Calibration

Calibration Frequency

While the D12 transmitter requires no periodic calibration, Combustible sensors should be zero and span calibrated every 3-6 months. The frequency of calibration may depend on environment factors. Sensors frequently exposed to dirt, oil mist, vapors, or very dry air, may require more frequent calibration.

Calibration Terminology

The zero calibration is referred to as, “zero”, “zeroing”, and “zeroed”. Likewise for the span calibration, which appears as, “span”, “spanning”, and “spanned”. As with most instruments, zero calibration should be performed before span.

Zero Calibration

As the name implies, zero calibration corrects the transmitter reading to zero - in the absence of any gas that causes a response by the sensor. During zero calibration, the transmitter offset error is stored, and subsequently subtracted from future readings. ATI recommends bottled zero air as a source, unless the atmosphere is known to be free of combustible gas, including Methane, Propane, Butane, Ammonia, Hydrogen, and more.

Span Calibration

The role of span calibration is to correct the transmitter reading to a known concentration of Methane, typically, 1% Vol (or 20%LEL). During span calibration, the transmitter effectively stores the slope of the error, and divides it out of subsequent readings.

Calibration Kits

Calibration kits containing Zero-air and Methane are available from ATI. Contact ATI, or your local ATI representative, if you have questions about calibration gas kits or gas sources.

Indications During Sensor Calibration

The “un-blanked” gas concentration value is displayed during zero and span calibration, primarily to observe any slight amount of positive or negative drift. In addition, alarms are cleared and inhibited, and the 4-20mA output of the D12 transmitter is locked at 4.0mA. The 4-20mA output will not change when gas is applied and removed, and for 15 minutes thereafter (the default value). While viewing the calibration pages, the LCD display will indicate the changing gas concentration.

Calibration Exceptions

Zero and span calibration are not allowed during the following conditions:

- ❖ Sensor removed, or in 5-minute⁴ warm-up period
- ❖ Transmitter fault is active
- ❖ Auto-test is active (“A” status indicator appears on Main Display page)

To help prevent errors, zero and span are not allowed if the sensor output, or span value entered, is too high or too low. Memory errors are reported if detected while updating the sensor or transmitter memory.

⁴ Typical value, may vary by sensor gas type.



Zero Calibration Procedure

Performing a zero calibration requires a cylinder of Zero-Air with a 500 cc/min regulator, calibration adapter, and a convenient length of 1/4" tubing. Referring to Figure 28, screw the calibration adapter onto the exposed end of the sensor and connect one end of the tubing (1), connect the other end of tubing to the cylinder's regulator (2). Do not open the gas valve until instructed below.

From the Main Display, select Menu, then Zero_Sensor, as shown in Figure 29. This will clear and inhibit alarms at the transmitter, and hold the current loop output at 4mA.

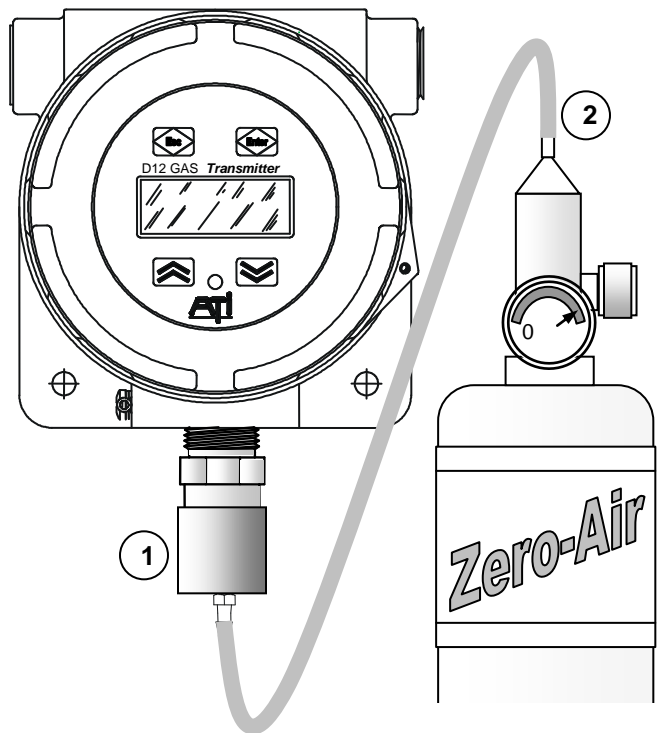

Figure 28. Zero calibration

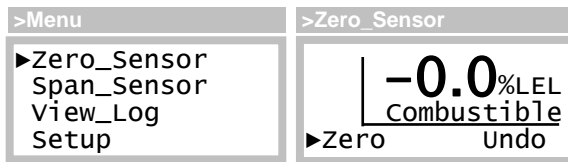

Figure 29. Zero Sensor page

Open the regulator to flow Zero-Air to the sensor. After approximately four minutes, select Zero. The “Cal” message will appear briefly at the bottom of the page and the reading will be forced to 0. Since the reading is not blanked, it may show a negative sign, like “-0”, which is normal. The procedure may be cancelled by selecting Undo. The Undo function is only possible while remaining on the Zero_Sensor page. Leaving the page will disable the possibility of canceling the calibration.

Touch the Escape key twice to leave the Zero_Sensor page and return to the Main page. By default, alarms will remain inhibited, and the current loop fixed for 15 more minutes (the default value).



Span Calibration Procedure

Span calibration* requires a cylinder of “span” gas with a 500 cc/min regulator, calibration adapter, and a convenient length of ¼” tubing. Referring to Figure 30: screw the calibration adapter onto the exposed end of the sensor and connect one end of the tubing (1), connect the other end of tubing to the cylinder’s regulator (2). Do not open the gas valve until instructed below.

* Perform the Zero calibration prior to the Span calibration.

From the Main Display, select Menu, then Span_Sensor, as shown in Figure 31. This will clear and inhibit alarms at the transmitter, and hold the current loop output at 4mA.

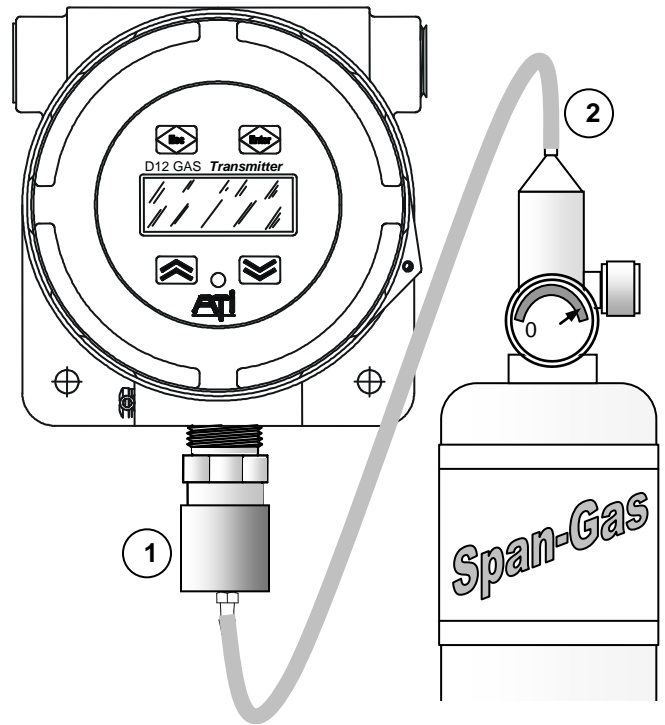

Figure 30 Span calibration

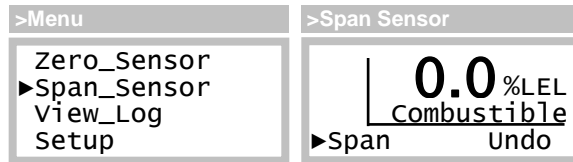
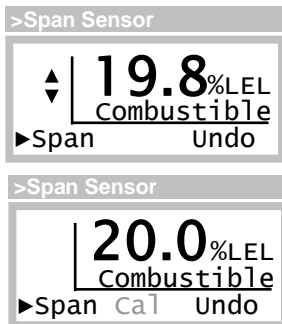

Figure 31. Span Sensor page

Open the regulator and allow span gas to flow to the sensor. Observe the displayed reading begins to increase, and at the end of four minutes, the reading should be stable.



Select Span, the concentration reading will become fixed, and the blinking Up/Dn edit cursor will appear just to the left of the reading. Touch the Up or Down key to correct the reading to match the known concentration of gas, then touch Enter.

The ‘Cal’ message will appear briefly at the bottom of the page. The procedure may be cancelled by selecting Undo. The Undo function is only possible while remaining on the Span_Sensor page. Leaving the page will disable the possibility of canceling the span calibration.

Touch the Escape key twice to leave the Span_Sensor page and return to the Main page. Disconnect the calibration adapter from the sensor and permit the readings to return to zero. By default, alarms will remain inhibited and the current loop fixed for 15 more minutes (the default value). Once the reading is below any of the alarm set points, you may terminate the alarm inhibit (and fixed loop output) using the Esc key on the Main Display (see Esc Key Operation (Main Display Page) in the Main Display Page section).



Spanning for OTM Gases (Other Than Methane)

Because the combustible gas sensor is normally calibrated for Methane, differences in the LEL and oxidation rates of other gases may lead to reading errors. These errors may be corrected by recalibrating the sensor span. The simplest method for correcting this error is to span calibrate with a bottle of the OTM gas, if available. In many cases, it may be more convenient to calibrate with Methane as a surrogate gas.

Spanning with OTM Gas (Other Than Methane)

The procedure for spanning to a known concentration of OTM gas is exactly the same as spanning for Methane, and detailed in the Span Calibration Procedure.

Spanning with Methane as a Surrogate Gas- Combustible Gas Sensor Only

In cases where the OTM gas is not available, you may use 1% Vol (20%LEL) Methane as a surrogate span gas, providing you “span to” the corresponding value shown in Table 5. Follow the Span Calibration Procedure above. After flowing Methane for four minutes, adjust the span value to match the value listed in the “Span To” column to the right of the OTM gas name.

**Table 5. OTM Gases (Other Than Methane) and Span To Values
(Used for spanning to 1%Vol (20%LEL) Methane – Combustible Gas Sensor Only)**

To Calibrate For:	Span To %LEL	To Calibrate For:	Span To %LEL
Acetone	50	Hydrogen	30
Ammonia	15	Isopropyl Alcohol	55
Benzene	55	Methane	20*
n-Butane	35	Methanol	30
Di-ethyl Ether	10	Methyl Ethyl Ketone	50
Ethanol	40	n-Pentane	40
n-Hexane	50	Propane	35
		Toluene	60

*Methane shown for comparison purposes.

Spanning for Safety – Combustible Sensor Only

It is usually best to avoid situations where the sensor may be exposed to more than one combustible gas at the same time, due to differences in LEL and oxidation rates between gases. In situations where it cannot be avoided, calibrate the sensor for the gas it is least sensitive to at the LEL. This will provide the highest margin of safety. Although a false alarm may result if a leak develops by one of the other gases, this strategy safeguards against potentially explosive conditions developing at the sensor location.

When comparing the “sensitivity” of the sensor to two or more gases, the sensor is less sensitive to gases with higher “Span To” values in Table 5 above. For example, consider monitoring for both Methane and Propane near a fuel storage site. From Table 5, you see that Propane’s “Span To” value is higher than that for Methane, so you would span calibrate to Propane using one of the two methods outlined above. Afterwards, the transmitter will report Propane accurately, but not Methane. However, if a Methane gas leak were to occur, the reading would be higher than the actual gas concentration and result in a false alarm. This results in a higher margin of safety when compared to “under-reporting” the Propane concentration. Alternatively, when monitoring for both Methane and Ammonia, leave the transmitter calibrated for Methane, since Methane’s “Span To” value is higher than that for Ammonia.



Sensor Calibration Records

A calibration record is written into the sensor memory each time a zero or span calibration is performed, and when a calibration Undo is performed. Enough memory is reserved for 63 zero calibrations and 63 span calibrations. Zero and span calibration records are accessed on the Cal_History page.

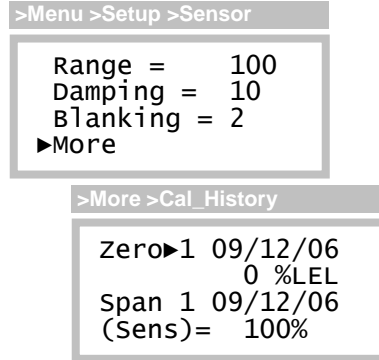

Figure 32. Sensor calibration history page

Zero calibration records are accessed on line 1, and are composed of an index number, date, and the concentration reading just prior to performing the calibration. The concentration reading can be thought of as the sensor “drift” from the previous zero calibration. Upon entry, the index number is set to the most recent calibration and may be scrolled down to view earlier calibration records.

Span calibration records are accessed on line 3, and include an index number, date, and the relative sensitivity of the sensor, in percent. Like the zero records, the index number is set to index the most recent calibration and may be scrolled down to view earlier calibration records. Span calibrations record the deviation from the reference sensitivity and display it in units of percent. Sensitivity is a measure of the sensor output for a given exposure to gas. More specifically, it is defined as the ratio of the signal output to the gas concentration and is often measured in mV/PPM. During manufacture, the sensitivity of the sensor is recorded and used as a reference. A value of 100% signifies that the sensitivity has not changed from the reference e.g., the sensor calibration is the same at it was when the system was calibrated at the factory. Lower values indicate a decreased sensitivity and, although not typical, higher values indicate increased sensitivity.



Auto-test

The Auto-test option requires the Combustible Sensor with the Auto-test Gas Generator.

Auto-test verifies the serviceability of the transmitter on a prescribed schedule by exposing the sensor to a small amount of gas, and verifying a minimum response. Three attempts per test are made, and if the sensor does not respond on the third attempt, a fault alarm is triggered (may be optionally disabled). A summary of pass, fail, and retry counts are maintained in the sensor memory, and may be viewed on the Auto-test History page.

The test is performed at a specific time of day, and may be scheduled to repeat every 1 to 14 days. The date and time of the next test is available for editing, and the test may be triggered manually at any time, without affecting the preset schedule.

During startup, the transmitter examines the date and time of the next scheduled Auto-test. If the scheduled time and date has past, or if it is scheduled to occur within the next 24 hours, the transmitter moves the date by one day to provide a minimum of 24 hours before the first (or next) test is performed. This is done to allow sensors an additional “settling time”, and to avoid confusion to installers during the commissioning period. Set the system clock to local time before scheduling the Auto-test time of day.

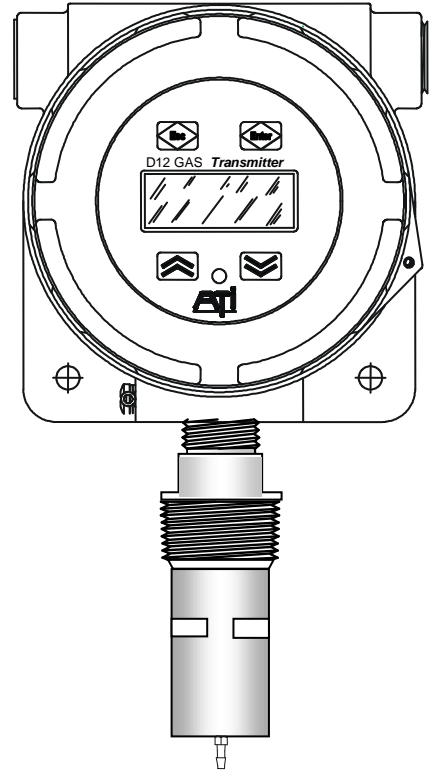

Figure 33. Combustible sensor with auto-test option



Auto-test Control Page

Auto-test is controlled by the Status variable, which appears on the Auto-test page shown below.

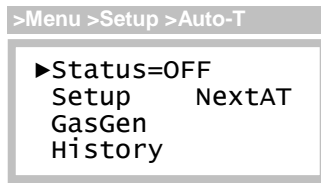

Figure 34. Auto-test control page

Table 6. Auto-test control variables

Variables	Description
Status	The variable Status may be set to one of three values: OFF – Auto-test will not begin automatically READY – Auto-test will occur on a regularly scheduled basis START – Auto-test will run once <u>after returning to the Main Display page</u> , and does not affect the preset schedule.

If a generator is not installed, Status will be forced to OFF, and may not be changed to READY or START until one is installed.

Setting the Status variable to START will not begin a manual Auto-test until you return to the Main Display page. This is designed to permit changes to the setting, or other settings, before launching the Auto-test sequence.

Auto-test Setup Page

The Auto-test setup page configures the Auto-test schedule pass threshold, and options for various transmitter indications.

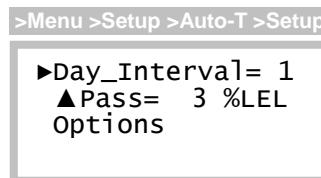

Figure 35. Auto-test setup page

Table 7. Auto-test setup variables

Variables	Description
Day_Interval	The Day_Interval variable specifies the number of days between automatic tests. The default is 1, and the limit is 1 to 14 (the exact time of day for testing may be set on the NextAT page, see below).
▲Pass	The delta-Pass variable specifies the amount by which the gas concentration must increase, in order to pass. Prior to starting the test, this amount is added to the “un-blanked” gas concentration reading to compute the pass threshold value that appears on the display (see Auto-test Sequence). This value is restricted to 3%LEL, and may not be modified.
Options	options is a link to the Auto-test Options page (below).



Auto-test Setup Options Page

```
>Menu>Setup>Auto-T>NextAT
▶Log_Data=YES
Cause_Fault=YES
Override_mA=YES
```

The Auto-test Setup Options page variables control the behavior of the transmitter during Auto-test.

Variables	Description
Log_Data	The Log_Data variable controls values logged during Auto-test. When set to YES (default), the gas concentration (main reading) is logged as usual, including any increase caused by the gas generator. When set to NO, a code is logged that will display as, "TEST", on graphic and tabular report pages, and printouts.
Cause_Fault	The Cause_Fault variable determines if Auto-test failures cause transmitter fault alarms. When set to YES (default), a failure to pass Auto-test after the third attempt will cause a fault alarm, and force the 4-20mA output to the Fault_mA value, regardless of how the test was initiated (automatic or manual). When set to NO, Auto-test failures do not cause fault alarms (not recommended).
Override_mA	The Override_mA variable controls the 4-20mA output during Auto-test. When set to YES (default), the 4-20mA output will be forced to the Autotst_mA value to prevent receiver alarms (see 4-20mA Setup Page). When set to NO, the output will increase as the gas concentration rises, and may cause receiver alarms (not recommended).

Next Auto-test Page

```
>Menu>Setup>Auto-T>NextAT
Next Auto Test
▶09/14/06 09:00
```

The date and time of the next scheduled Auto-test appears on the NextAT page. The time appearing on this page establishes the time of day for all future Auto-tests. After each Auto-test, the date will be incremented by the Day_Interval variable on the Auto-test Setup page (above). Note that if the Auto-test Status variable is set to READY, and the next auto-test setting is deliberately (or unintentionally) scheduled in the past, an Auto-test is immediately scheduled. This is apparent upon returning to the Auto-test control page (above), and seeing the Status variable blinking START. At this point, you may change the control to OFF, change the system clock, then change the control back to READY.

During startup, the transmitter examines the date and time of the next scheduled Auto-test. If the scheduled time and date has past, or if it is scheduled to occur within the next 24 hours, the transmitter moves the date by one day to provide a minimum of 24 hours before the first (or next) test is performed. Set the system clock to local time before scheduling the Auto-test time of day.



Auto-test History Page

```
>Menu>Setup>Auto-T>History
Passes=    267
Failures=    1
Retries=    2
▶Reset(Y/N)=NO
```

The Auto-test History page provides a summary of passes, failures, and retries, which are maintained in the sensor memory. Since three attempts are made, there are always two retries before a failure is recorded. The total number of tests is the sum of the passes and failures, and the number of gas generations is the sum of all three values.

The Reset function permits all counts to be zeroed. This is done by selecting Reset, and scrolling the value to YES. Clearing the counts is not recommended, since this information can prove useful over the lifetime of the sensor.

Gas Generator Page

```
>Menu>Setup>Auto-T>GasGen
17.3 Combustible
3%LEL 100mA
0.07mAH Used
▶Exit
```

The Gas Generator page lists information about the C18 gas generator. The top line contains the generator gas code and the chemical abbreviation of the gas. The second line shows the delta-Pass value (described on the Auto-test Setup Page), and the amount of current required. The third line displays the mAH consumption of the generator. Selecting the Exit function returns the display to the previous page.

Auto-test Sequence

When the Auto-test starts (automatically or manually), alarms are inhibited and by default, the loop is fixed at 4mA (see 4-20mA Setup on page 53). The transmitter will then step through a series of displays representing the test sequence.

Alarm relays are inhibited during Auto-test, and for up to 10 minutes afterwards during the recovery period. If a gas leak occurs during the recovery period, will cancel the alarm inhibit and revert to normal operation. A gas leak is presumed when the concentration rises to 50% of the full-scale range, or higher.

While the alarms are inhibited during Auto-test, the 4-20mA output will usually be at a fixed level (Override_mA=YES). The output override may be disabled by setting Override_mA=NO, however, steps should be taken to disable receiver alarms in the control room.

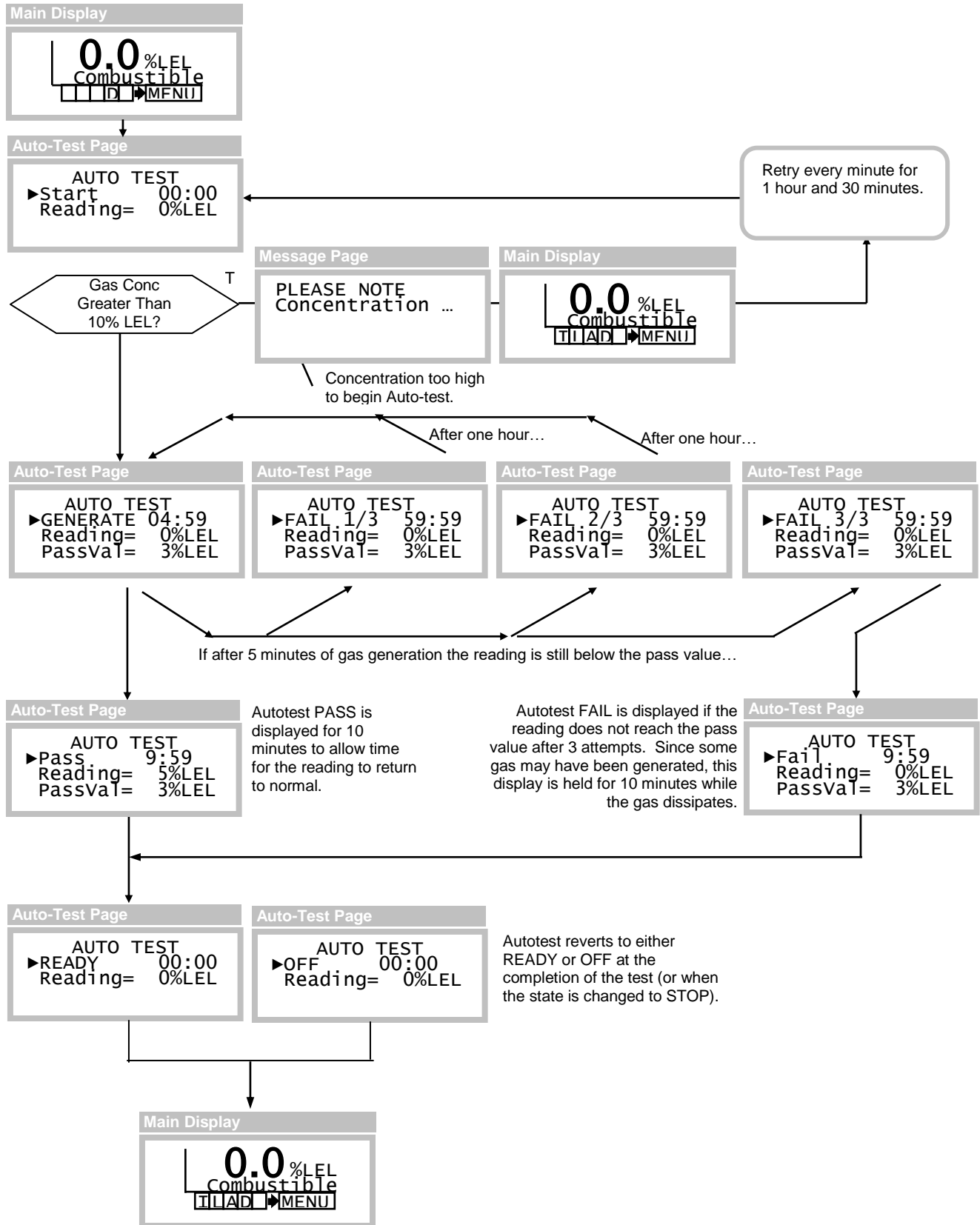

Figure 36. Auto-test sequence

ALARMS and RELAYS

Alarms are standard in the D12 transmitter, regardless of the optional relays. The alarm status indicators appear on the Main Display, and status is available over the optional serial interface. Alarms may be assigned to activate one or more of the three optional relays, which are discussed below in Alarm Relays.

Gas Concentration Alarms

The gas alarms are labeled, Caution, Warning, and Alarm, and although not strictly enforced, Alarm usually has the highest priority, followed by Warning and Caution. Figure 37 depicts the default relationship between each alarm.

For the combustible gas sensor, no alarm may be set higher than 60%LEL. The default setting for the Warning alarm is 20%LEL, and 50%LEL for Alarm. Caution is used to alarm on negative drift of –10%LEL or more (a fault alarm occurs if the reading drifts to –20%LEL, or below).

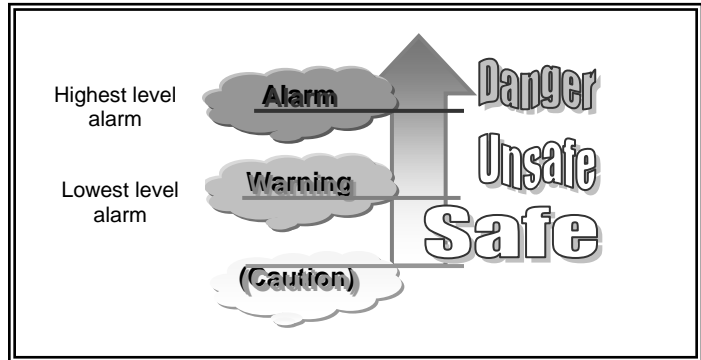

Figure 37. Default alarm relationships for combustible gas sensors

Manual Alarm Reset

Alarms programmed for manual reset (see below) are held active, or latched, even after alarm conditions have subsided. On the combustible sensor version of the transmitter, Alarm is always programmed for manual reset. Latched alarms are reset from the Main Display page by selecting the respective flag (A, W, or C). The Alarm Reset page appears and displays the date and time of the alarm. If alarm conditions have subsided, you may reset just the selected alarm (Reset), or all alarms (ResetAll). A link to the Alarm Inhibit page is provided for convenience.

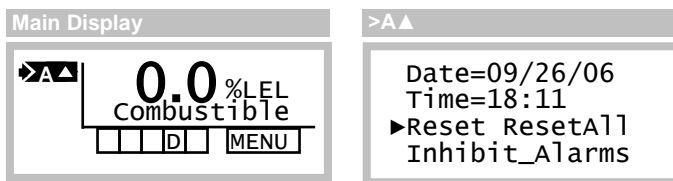

Figure 38. Manual alarm reset

Remote Reset

Grounding the “Remote Reset” input (see Power Supply Board) resets all latched alarms, if the respective alarm conditions have subsided.



Gas Alarm Setup Pages

Variables for the gas alarms are configured on the respective setup pages, as shown in Figure 39, and described in Table 8.

▶Alarm Warning Caution Inhibit	<table border="1"> <tr><td>Relays</td></tr> <tr><td>Setup</td></tr> <tr><td>Test</td></tr> </table>	Relays	Setup	Test													
Relays																	
Setup																	
Test																	
<table border="1"> <tr><td>>Alarm</td></tr> <tr><td>Active=ABOVE_SP</td></tr> <tr><td>Set_Point= 50</td></tr> <tr><td>Res_Point= 50</td></tr> <tr><td>▶More</td></tr> </table>	>Alarm	Active=ABOVE_SP	Set_Point= 50	Res_Point= 50	▶More	<table border="1"> <tr><td>>Warning</td></tr> <tr><td>Active=ABOVE_SP</td></tr> <tr><td>Set_Point= 20</td></tr> <tr><td>Res_Point= 20</td></tr> <tr><td>▶More</td></tr> </table>	>Warning	Active=ABOVE_SP	Set_Point= 20	Res_Point= 20	▶More	<table border="1"> <tr><td>>Caution</td></tr> <tr><td>Active=BELOW_SP</td></tr> <tr><td>Set_Point= -10</td></tr> <tr><td>Res_Point= -10</td></tr> <tr><td>▶More</td></tr> </table>	>Caution	Active=BELOW_SP	Set_Point= -10	Res_Point= -10	▶More
>Alarm																	
Active=ABOVE_SP																	
Set_Point= 50																	
Res_Point= 50																	
▶More																	
>Warning																	
Active=ABOVE_SP																	
Set_Point= 20																	
Res_Point= 20																	
▶More																	
>Caution																	
Active=BELOW_SP																	
Set_Point= -10																	
Res_Point= -10																	
▶More																	
<table border="1"> <tr><td>>Alarm >More</td></tr> <tr><td>▶Reset=MANU</td></tr> <tr><td>Fault_Goto=HOLD</td></tr> <tr><td>Set_Delay=0</td></tr> </table>	>Alarm >More	▶Reset=MANU	Fault_Goto=HOLD	Set_Delay=0	<table border="1"> <tr><td>>Warning >More</td></tr> <tr><td>▶Reset=AUTO</td></tr> <tr><td>Fault_Goto=HOLD</td></tr> <tr><td>Set_Delay=0</td></tr> <tr><td>Res_Delay=0</td></tr> </table>	>Warning >More	▶Reset=AUTO	Fault_Goto=HOLD	Set_Delay=0	Res_Delay=0	<table border="1"> <tr><td>>Caution >More</td></tr> <tr><td>▶Reset=AUTO</td></tr> <tr><td>Fault_Goto=HOLD</td></tr> <tr><td>Set_Delay=0</td></tr> <tr><td>Res_Delay=0</td></tr> </table>	>Caution >More	▶Reset=AUTO	Fault_Goto=HOLD	Set_Delay=0	Res_Delay=0	
>Alarm >More																	
▶Reset=MANU																	
Fault_Goto=HOLD																	
Set_Delay=0																	
>Warning >More																	
▶Reset=AUTO																	
Fault_Goto=HOLD																	
Set_Delay=0																	
Res_Delay=0																	
>Caution >More																	
▶Reset=AUTO																	
Fault_Goto=HOLD																	
Set_Delay=0																	
Res_Delay=0																	

Figure 39. Alarm setup pages (example)



Table 8. Alarm variables

Variable	Description
Active	The Active variable is used to specify the concentration range where the alarm is active. When set to ABOVE_SP, the alarm becomes active at and above the set point (referred to as a rising alarm). When set to BELOW_SP, the alarm becomes active at and below the set point (referred to a falling alarm). Setting the value to DISABLED permanently deactivates the alarm. The variable setting is stored in the transmitter memory.
Set_Point	The Set_Point variable defines the concentration level that the alarm becomes active. The alarm becomes active immediately if the set delay variable is 0, otherwise, it becomes active at the expiration of the set delay period. When the set point is reprogrammed, the reset point value is also reprogrammed to the same value.
Res_Point	The Res_Point variable defines the concentration level that the alarm becomes inactive. Once the alarm is active, it will remain active until the concentration level reaches the reset point. The alarm then becomes inactive immediately if the set delay variable is 0, otherwise, the alarm becomes inactive at the expiration of the reset delay period (only if the reset variable is programmed as AUTO – see below). The limits for the reset point are defined below. Active=ABOVE_SP Upper limit = current set point value Lower limit = lowest set point value Active=BELOW_SP Upper limit = highest set point value Lower limit = current set point value When the set point is reprogrammed, the reset point value is reprogrammed to the same value.

Reset The Reset variable defines how the alarm is permitted to transition from active, to inactive. When the variable is set to AUTO, the alarm will transition without operator intervention, as soon as conditions permit (concentration reaches the reset point, and the reset delay period expires). When the variable is set to MANU, the reset conditions must prevail, and an operator must acknowledge the alarm manually, through the operator interface, the serial interface, or through the remote reset (see Electrical Connections, page 12). On the combustible sensor version of the transmitter, Alarm is restricted to MANU only.

Note: Res_Delay is operational for AUTO only. Setting the Reset variable to MANU suppresses display of the Res_Delay variable.

Fault_Goto The Fault_Goto variable specifies alarm behavior during transmitter faults, and overrides all other alarm settings. If the fault alarm should become active, you may program the concentration alarm to behave in one of three ways:
 HOLD - the transmitter will attempt to hold the alarm in its current state. If the alarm is active, it will remain active. If the alarm is inactive, it will be inhibited from becoming active until after the fault is cleared.
 SET - activates the alarm immediately, the set delay period is ignored. This feature permits the alarm to signal both concentration and fault conditions.
 RESET – deactivates the alarm immediately, the reset delay period is ignored.

Set_Delay The set delay variable is used to configure the amount of time in seconds that the concentration must be in the alarm active region before becoming active. It may be used to avoid triggering alarms on relatively short gas exposures. Also, it may be used to help prevent alarm relay chattering when the concentration level is varying between the set point and reset point. The variable may be programmed between 0 (its default) and 10 seconds.

Res_Delay The reset delay variable is only displayed when the Reset variable is set to AUTO. It is used to configure the amount of time in seconds that the concentration must be in the alarm inactive region before becoming inactive. Like the set delay variable, it may be used to help prevent alarm relay chattering and is preferred over using set delay. The variable may be programmed between 0 (its default) and two hours (7200 seconds).

Alarm Variable Functions

Figure 40 depicts relationships between variables associated with a rising gas alarm, and how they function in the presence of a gas leak, and recovery.

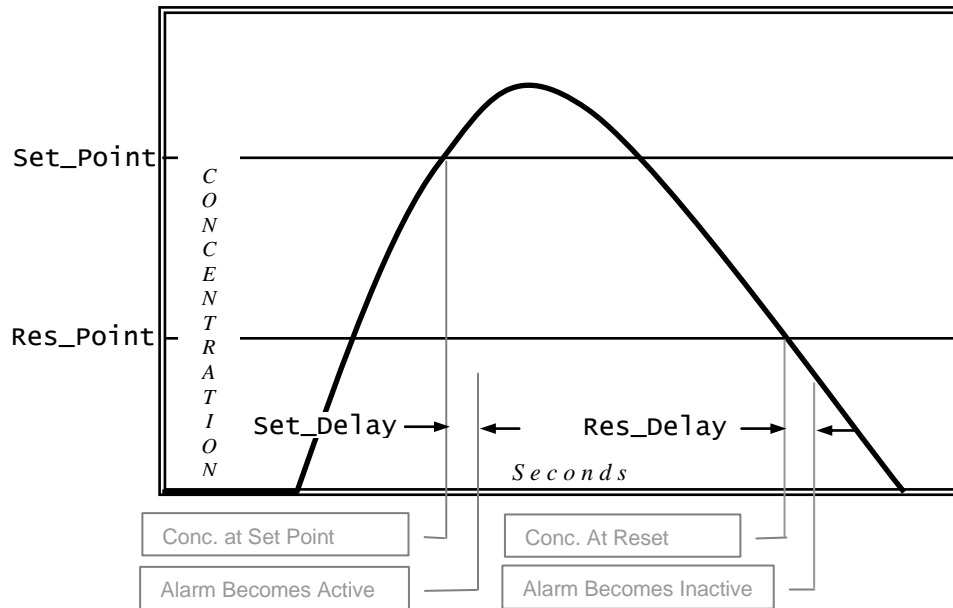

Figure 40. Rising alarm (Active=ABOVE SP, Reset=AUTO)

Figure 41 depicts relationships between variables associated with a falling gas alarm (such as for Oxygen deficiency), and how they function in the presence of a gas displacement, and recovery.

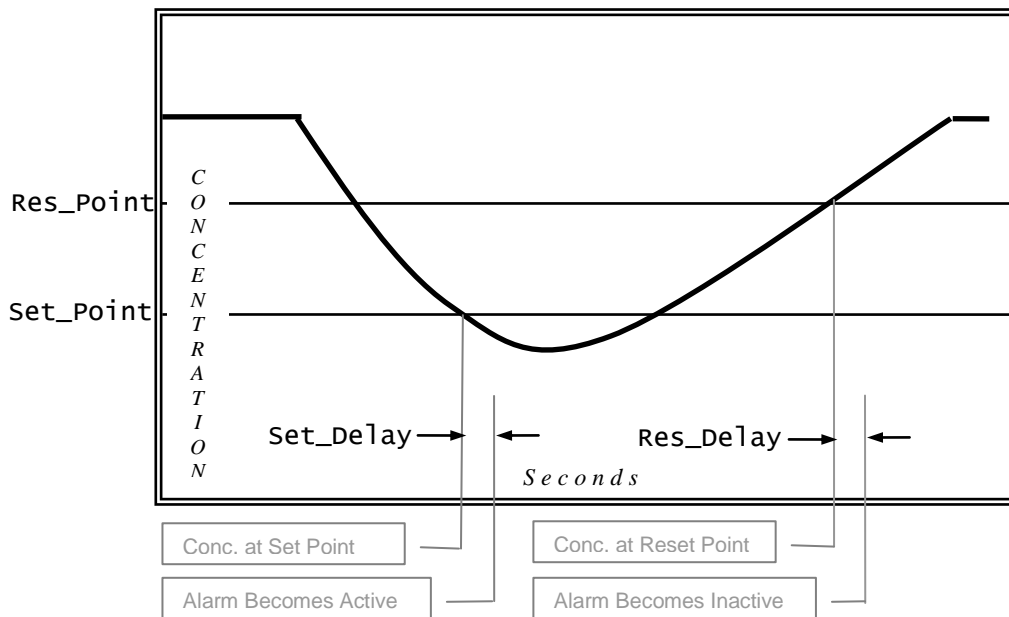

Figure 41. Falling alarm (Active=BELOW SP, Reset=AUTO)



Fault Alarms

When a fault alarm occurs, the Main Display appears as shown below. By default, new alarms are inhibited, and active alarms are held so that relays controlling lights, sirens, and fans may continue to operate (this behavior may be modified on the Alarms Setup pages). Faults are permitted to clear automatically, without operator intervention, if they do not persist.

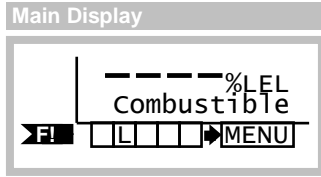

Figure 42. Fault alarm (Main Display)

Selecting the fault alarm flag causes the transmitter to display the fault code on line 1, and a description of the problem(s) on line 2. Selecting the Next function causes line 2 to display the next fault, if any.

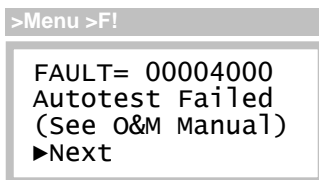

Figure 43. Fault page

Corrective Actions

Improper wiring, ground loops, power supply sizing, current loop receivers, and other external factors may cause transmitter faults.

1. At power on, transmitters can demand 2 or 3 times the normal amount of supply current. If the supply is not sized properly, transmitters may not power on, or may produce a fault in the external power supply. If this is suspected, try starting transmitters one at a time using switch SW5 on the CPU Board.
2. Check that each transmitter has the proper supply voltage at TB1 on its Power Supply Board. The D12 Combustible Gas Transmitter requires at least 10v in all wiring modes.
3. When troubleshooting, it is permissible to temporarily swap sensors, generators, and board stacks with other transmitters. When finished, you **MUST RE-VERIFY** all transmitter settings, especially sensor, alarm, and 4-20mA settings. Also note that swapping components may result in losing data log records, since the log is dependent on sensor part numbers, and the full-scale range.

Table 9 lists transmitter faults and corrective actions.

Table 9. Fault descriptions

Fault	Description	Corrective Action(s)
ADC0 Read Error	The analog-to-digital converter channel assigned to the sensor's gas concentration output signal has failed, or is out of range.	<ol style="list-style-type: none"> 1. Cycle power off and on 2. Replace sensor 3. Replace upper stack 4. Replace full stack
LCD Busy Error	The LCD driver chip cannot recover from an internal error.	<ol style="list-style-type: none"> 1. Cycle power off and on 2. Replace upper stack 3. Replace full stack



SPI Bus Error	Serial peripheral interface bus has faulted.	<ol style="list-style-type: none">1. Cycle power off and on2. Replace upper stack3. Replace full stack
ADC1 Read Error	The analog-to-digital converter channel assigned to the sensor's temperature output signal has failed, or is out of range.	<ol style="list-style-type: none">1. Cycle power off and on2. Replace sensor3. Replace upper stack4. Replace full stack
Sensor (-)Range	The sensor has drifted -20% range (below zero).	<ol style="list-style-type: none">1. Zero sensor2. Replace sensor
Sensor Removed	The sensor cannot be detected.	<ol style="list-style-type: none">1. Reinstall sensor2. Cycle power off and on3. Replace sensor4. Replace upper stack5. Replace full stack
Sensor Mem Error	One or more configuration variables in the sensor memory do not pass checksum test.	<ol style="list-style-type: none">1. Cycle power off and on2. Replace sensor3. Replace upper stack4. Replace full stack
Sensor Cfg Error	One or more sensor configuration variables are outside of expected range.	<ol style="list-style-type: none">1. Cycle power off and on2. Replace sensor3. Replace upper stack4. Replace full stack
Gas Gen Removed	The generator cannot be detected.	<ol style="list-style-type: none">1. Install generator2. Cycle power off and on3. Replace generator4. Replace sensor5. Replace upper stack6. Replace full stack
Gen Incompatible	The gas generator is not compatible with the installed sensor type or range.	<ol style="list-style-type: none">1. Replace generator2. Change sensor range3. Replace sensor4. Replace upper stack5. Replace full stack
System Mem Error	A checksum error has been detected in the system setup memory.	<ol style="list-style-type: none">1. Cycle power off and on2. Replace upper stack3. Replace full stack
Alarm Mem Error	A checksum error has been detected in the alarm setup memory.	<ol style="list-style-type: none">1. Cycle power off and on2. Replace upper stack3. Replace full stack
Operator Mem Err	A checksum error has been detected in the operator setup memory.	<ol style="list-style-type: none">1. Cycle power off and on2. Replace upper stack3. Replace full stack
HART Mem Error	A checksum error has been detected in the HART setup memory.	<ol style="list-style-type: none">1. Cycle power off and on2. Replace upper stack3. Replace full stack



Autotest Failed	Auto-test failed after 3 attempts.	<ol style="list-style-type: none">1. Replace generator2. Replace sensor3. Replace upper stack4. Replace full stack
Use 3-wire Power	Relay option jumper is installed, but transmitter is powered from loop (2-wire).	<ol style="list-style-type: none">1. If relays are not used, remove jumper.2. Re-wire transmitter in 3- or 4-wire mode.3. Replace upper stack4. Replace full stack
Stack Overflow	An internal error occurred in the CPU.	<ol style="list-style-type: none">1. Cycle power off and on2. Replace upper stack3. Replace the full stack
Factory Cal Err	An error has been detected in the factory calibration memory.	<ol style="list-style-type: none">1. Cycle power off and on2. Replace upper stack
UNCALIBRATED	This appears on the Main Display, in place of the gas name, when the transmitter has not been factory calibrated, or the calibration memory has become corrupted.	<ol style="list-style-type: none">1. Cycle power off and on2. Replace upper stack3. Replace the full stack
Fault Alarm Test	This is not a real fault. This occurs when the fault alarm is being tested locally, or remotely.	

Alarm Relays

The D12 transmitter provides three optional SPDT mechanical relays rated for 5 amps, non-inductive loads at 250VAC. These relays are suitable for switching small loads, such as horns and warning lights, but should not be used to switch motors or other high current, inductive loads.

Each relay is assigned to one of the four alarms, and may be programmed as normally energized (failsafe), or normally de-energized. A normally energized relay will have electrical continuity between its C and NO contacts (while the transmitter is powered on), and will be open between its C and NC contacts. Conversely, a normally de-energized relay will have continuity between its C and NC contacts, and will be open between its C and NO contacts. Figure 44 illustrates the function of alarm and relay variables on the operation of the relays.

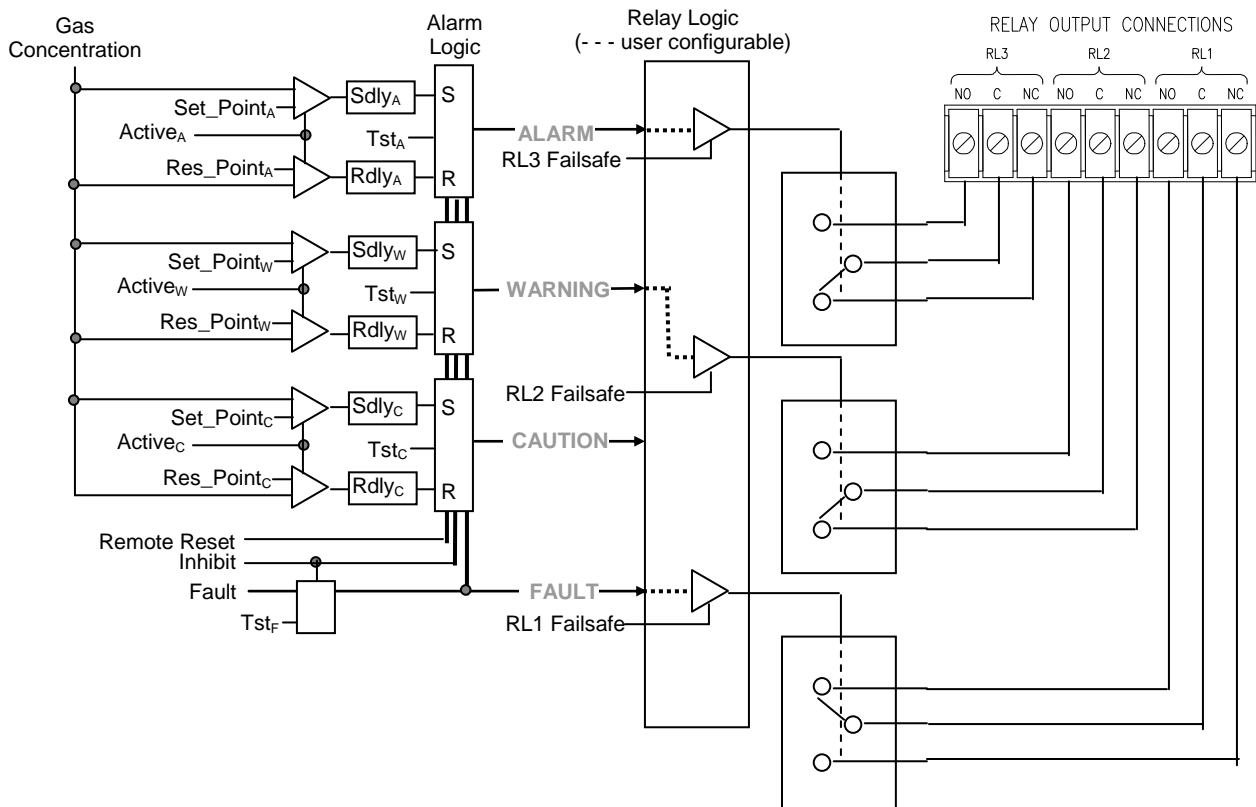

*Figure 44 Alarm relay schematic
(default configuration – no alarms active)*



Relay Setup Page

Relays are configured in the Relays Setup page, which is accessed by selecting Menu, Setup, Alarms, and (Relays) Setup. Select the alarm trigger source (Alarm, Warning, Caution, Fault), and failsafe property (Normal-On or Normal-Off).

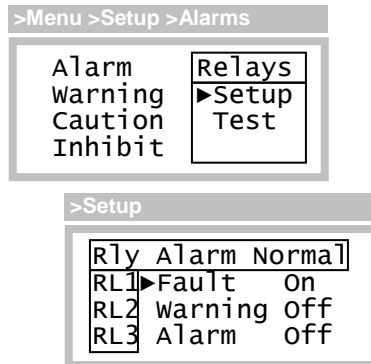



Figure 45. Relay setup page (example)

Testing Alarm Relays

Relays are tested by triggering (simulating) their assigned alarms on the Relay Test page. To trigger an alarm, scroll the “Select” variable up and down until an X appears below the letter representing the alarm. Save the selection by touching the Enter key, and move the cursor to the function labeled “Start”.

<p>Caution: devices wired to the relays may activate when “Start” is selected. Be sure to inform proper personnel before performing the test.</p>	
--	---

When ready, select “Start” to begin the test. “Start” will be replaced by, “Any key to Stop”, and touching any key will end the test.

Relay Test Page

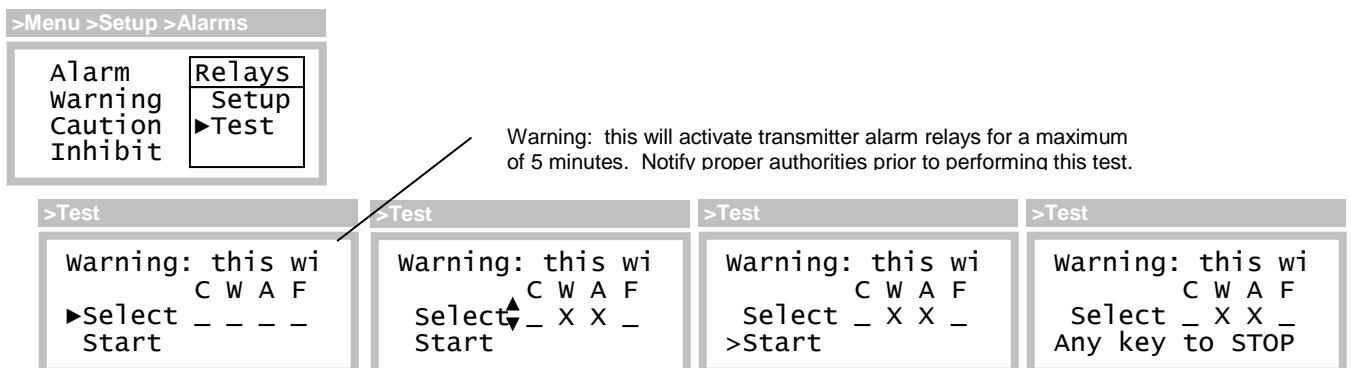

Figure 46. Relay test page example



Inhibiting Alarms

Alarms should be inhibited to prevent false activation, such as done just prior to “bump-testing” the sensor.

The most convenient method for temporarily inhibiting alarms is from the Main Display. Hold the magnet over the ESC key for 2 seconds, and remove it. This will toggle the alarm inhibit mode on for 15 minutes, which will clear and inhibit alarms, hold the current loop at 4mA, and cause the “I” and “L” status indicators to appear. Repeating the procedure toggles alarm inhibit mode off immediately, restores the current loop to normal operation, and clears the “I” and “L” status indicators. Both the inhibit duration, and loop output, are programmable and may be accessed on the Alarm Inhibit setup page (see below).

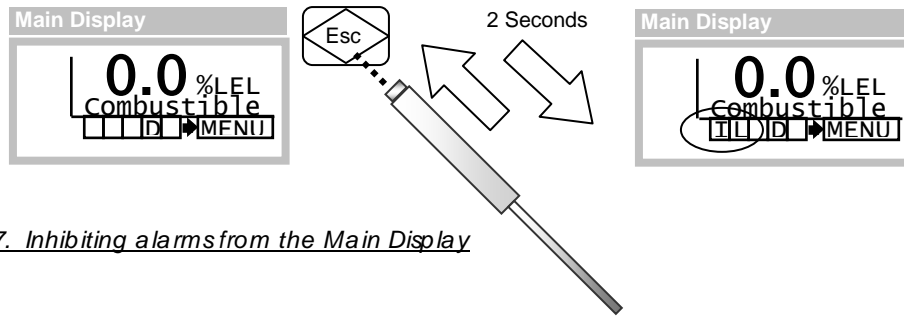

Figure 47. Inhibiting alarms from the Main Display

Alarm Inhibit Setup page

Variables and controls associated with the alarm inhibit mode are accessible on the Alarm Inhibit setup page (below), and are detailed in Table 10.

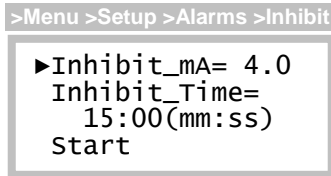

Figure 48. Alarm inhibit setup page

Table 10. Alarm inhibit variables and controls

Variables	Description
Inhibit_mA	The Inhibit_mA variable is output on the current loop during alarm inhibit. It ranges from 3.5 to 22.0 mA (this is the same value that appears on the 4-20mA Setup page).
Inhibit_Time	Alarm Inhibit Off The Inhibit_Time variable is the duration of the alarm inhibit mode, and is programmable from 00:00 to 99:59 (mm:ss). Alarm Inhibit On: The variable counts down from its programmed duration. Selecting it temporarily freezes the count and permits it to be scrolled up and down. If Enter is touched, counting resumes from the new value. If Esc is touched, counting resumes at the previous value. These changes are temporary, and are not saved as the programmed value.
Start (Stop)	The Start function turns on alarm inhibit, which clears and inhibits alarms, holds the current loop at 4mA, causes the “I” and “L” status indicators to appear, and starts the Inhibit_Time variable to begin ticking down. The label then changes to “Stop”, and selecting it again turns off alarm inhibit, restore the current loop to normal operation, clears the “I” and “L” status indicators, and restores the Inhibit_Time variable to its programmed value.

4-20mA Output

The 4-20mA output normally sources positive current to a receiver, proportional to the main reading. The output is 4 mA at zero, and rises to 20mA at the full-scale range (see “Range” variable in Sensor Setup Page), and may go as high as 24mA (125%LEL) in case of gas flooding. Since the reading is blanked below zero, the output should never go below 4mA in the course of normal operation.

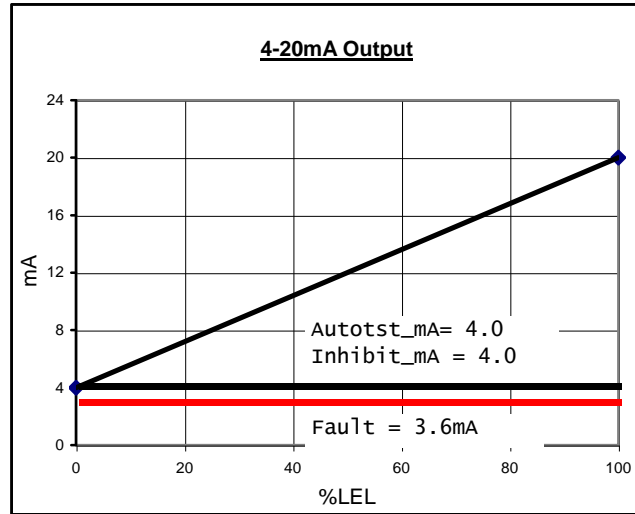

Figure 49. Current loop output plot

Output Overrides

By default, the output is forced to 3.6mA to signal fault alarms to the receiver. During alarm inhibit and auto-test modes, the loop is fixed at 4.0mA to prevent false alarms at the receiver. These are the default values, which may be changed on the 4-20mA Setup page shown in Figure 50.

4-20mA Setup Page

Variables listed on this page are described in

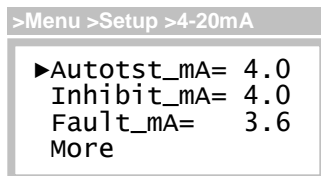

Figure 50. 4-20mA setup page

Table 11. 4-20mA variables

Variables	Description
Autotst_mA	The Autotst_mA variable is the mA value output during Auto-test mode – to prevent false alarms at the receiver. The default is 4.0mA, and is limited between 3.5 ⁵ and 22.0 mA.
Inhibit_mA	The Inhibit_mA variable is the mA value output during the Alarm Inhibit mode – to prevent false alarms at the receiver. The default is 4.0, and is limited between 3.5 ² and 22.0 mA.
Fault_mA	The Fault_mA variable is the mA value output during Fault alarms. The default is 3.6mA, and is limited between 3.5mA ² and 22.0mA. The value should be recognized as a fault by the loop receiver.
More	More is a link to the 4-20mA control page.

⁵ Since the transmitter may be powered from the current loop, 3.5mA is the lower limit for all settings.



4-20mA Control Page

The 4-20mA Control page permits adjustment of the analog output, and provides a method for manually forcing it to a fixed value to overcome leakages, verify linearity, or test receiver alarms.

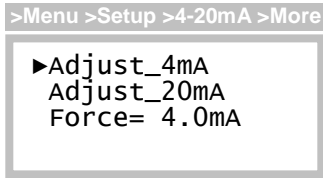

Figure 51. 4-20mA control page

Table 12. 4-20mA control variables

Variables	Description
Adjust_4mA	The Adjust_4mA variable is used to adjust the 4mA level on the 4-20mA output.
Adjust_20mA	The Adjust_20mA variable is used to adjust the 20mA level on the 4-20mA output.
Force	The Force variable is used to force the 4-20mA output to a fixed value. While the variable is not selected, the displayed value is updated to show the real-time output level. The loop is fixed at the instant the variable is selected, and the value may be scrolled up and down as desired, between 3.5 and 22.0 mA.

Loop Adjustment

Loop adjustment consists of adjusting the 4 and 20 mA levels (order does not matter) by scrolling the corresponding DAC⁶ value. This may be accomplished by reading a current meter connected across the mA(+) and mA(-) terminals of TB1 on the transmitter’s Power Supply Board, or reading the display of a calibrated, current loop receiver.

Warning:
Disable current loop receiver alarms before proceeding.

Select Adjust_4mA or Adjust_20mA and observe the following displays. Select DAC_Value and scroll the displayed value up and down to achieve the desired output level, and touch Enter to save, or Esc to exit without saving.

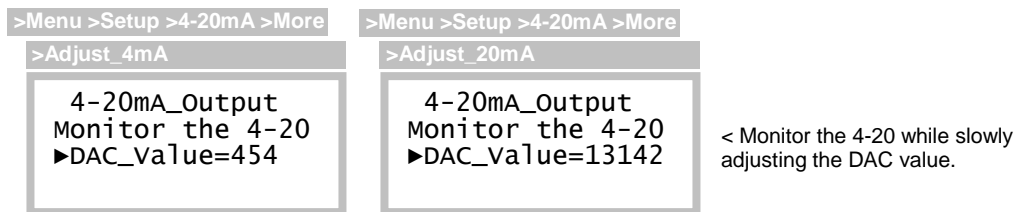

Figure 52. Loop adjustment pages (DAC values shown may not match)

⁶ Digital-to-Analog-Converter value ranging 0 to 16383 (14-bits). Adjustment is performed at factory, values will vary from transmitter to transmitter. This range may increase on future versions.

DATA LOG

The D12 transmitter data log records gas concentration in one of 12 discrete intervals ranging from 1 to 60 minutes, providing data from 11 to 474 days. Table 13 details sampling intervals and the associated metrics.

Table 13. Data-log sampling metrics

Sampling (Minutes)	Samples/Day	Days
1	1440	11
2	720	22
3	480	32
4	360	43
5	288	54
6	240	64
10	144	104
12	120	124
15	96	152
20	72	196
30	48	278
60	24	474

Gas concentration (see Main Reading) is recorded as an instantaneous value, and is not averaged or filtered in any way. When the data log memory is filled, new records will overwrite older ones.

Data-log Access Page

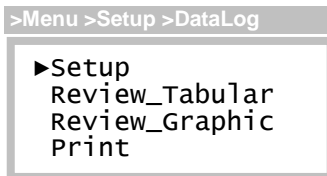

The Data Log Access page provides links to pages described below.

Figure 53. Data log access page

Data-log Setup Page

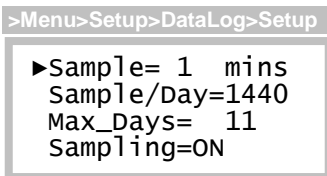

The Data Log Setup page provides variables used to select one of the 12 discrete sampling intervals listed in Table 13, and a control for starting and stopping data-logging, and clearing the data log.

Figure 54. Data log setup page

Table 14. Data-log setup variables

Variables	Description
Sample, Sample/Day, Max_Days	These variables are used to select one of the 12 sampling intervals listed in Table 13. Each variable functions identically. Scrolling any one of the variables updates the other two. Warning: changing the sampling interval will clear the data-log.
Sampling	The Sampling variable is used to control data recording, which starts when set to ON, and stops when set to OFF. The data-log is cleared when set to CLR, after which the control is returned to its previous value (ON or OFF).



Data may be displayed on the LCD graphically, or in a tabular report format. Data may also be output to a terminal, terminal program, or serial printer. Dates formats are configurable as MM/DD or DDMMM (see System Clock), and samples are displayed in the concentration units shown on the Main Display Page.

In place of numeric data samples, a report may display special text to indicate samples were unavailable, not yet sampled, or some condition prevented sampling.

Table 15. Data log special text

Special Text	Description
----	Sample unavailable (transmitter powered off, or sample not yet recorded)
FFFF	Fault alarm active at time of sample
TEST	Auto-test active at time of sample (if Log_Data=NO, see Auto-test Setup Options Page)
CLNR	Auto-clean option active at time of sample (Wet-H ₂ S sensor, only)
****	Data is corrupted, or unreliable

Data-log Graphic Report Page

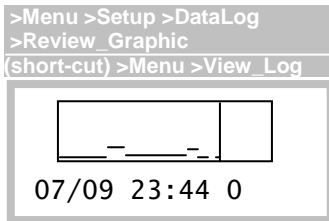

The Graphic Report page plots samples on the LCD from left to right, where older samples are on the left, and newer samples are to the right. Touching the Up and Down keys moves the vertical cursor line right and left, respectively, while updating the date, time, and sample data text on the bottom line.

Figure 55. Data log graphic report page

Upon entry, the cursor is parked at the most recent sample. Moving the cursor left displays the date, time, and values of earlier samples (moving it right will show “- - -”, not sampled yet). Touching the Enter key switches to the Tabular Report page, shown below, and touching the Esc key returns to the Menu page. Data is not plotted while viewing the page.

Data-log Tabular Report Page

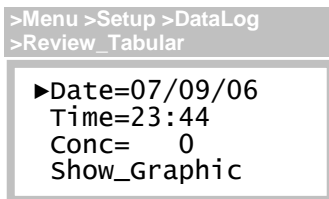

The Tabular Report page displays samples in the text field labeled “Conc”(gas concentration) and provides direct access to data by scrolling to an exact date and time.

Figure 56. Data log tabular report page



Upon entry, the Date, Time, and Conc variables are set to the most recent sample. Scrolling the Time variable up increments it by the sampling interval, and causes the next, successive sample to be displayed at Conc. Scrolling Time down displays the previous sample time, and value. Scrolling Time up and down will cause a date rollover at midnight. Scrolling the Date variable up increments it by one day, while holding the Time variable fixed. This is an expedient method to access specific data, and is useful for examining samples recorded at the time of day.

Once the date and time are set, select the Show_Graphic link to switch to the Graphic Report page. Data is not updated while viewing the page.

Data-log Printout

Data-log reports may be sent to serial printer, terminal, or terminal emulation program, such as Microsoft Hyperterminal®. See Appendix A. details on how to setup and print reports.

Figure 57. Data-log printout

<i>Date</i>	<i>Time</i>	<i>S0</i>	<i>S1</i>	<i>S2</i>	<i>S3</i>
07/09/06	22:40	1	0	0	1
07/09/06	22:44	-0	0	0	-0
07/09/06	22:48	1	TEST	TEST	TEST
07/09/06	22:52	TEST	TEST	TEST	TEST
07/09/06	22:56	TEST	TEST	TEST	TEST
07/09/06	23:00	1	0	0	1
07/09/06	23:04	1	0	0	1
07/09/06	23:08	1	0	0	1
07/09/06	23:12	1	0	0	1
07/09/06	23:16	1	1	1	0
07/09/06	23:20	0	0	0	-0
07/09/06	23:24	-0	0	0	0
07/09/06	23:28	----	----	----	----
07/09/06	23:32	----	----	----	----
07/09/06	23:36	----	----	----	----
07/09/06	23:40	FFFF	FFFF	0	0



DISPLAY

The D12 Transmitter features a backlit, 96w x 32h graphics LCD.

Display Setup Page

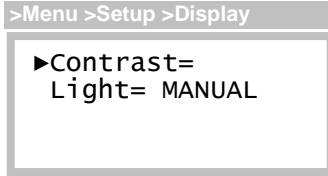

The Display Setup page variables are used to control the display contrast, and manage the backlight.

Table 16. Display page variables

Variables	Description										
Contrast	The Contrast variable is used to adjust the LCD contrast. Scroll the variable up to increase contrast (darker text), or down to decrease it (lighter text). The default value is 68%, and is adjustable between 0 and 100%.										
Light	The Light variable is used to control when the LCD backlighting is turned on and off.										
	<table border="1"> <thead> <tr> <th>Setting</th> <th>Backlight is ...</th> </tr> </thead> <tbody> <tr> <td>MANUAL</td> <td>On when any key is touched Off when no key touched for 5 minutes</td> </tr> <tr> <td>AUTO</td> <td>On when any key is touched or alarm is active Off when no key touched for 5 minutes, and no alarms active</td> </tr> <tr> <td>NEVER_ON</td> <td>Off permanently</td> </tr> <tr> <td>ALWAYS_ON</td> <td>On permanently (not recommended)</td> </tr> </tbody> </table>	Setting	Backlight is ...	MANUAL	On when any key is touched Off when no key touched for 5 minutes	AUTO	On when any key is touched or alarm is active Off when no key touched for 5 minutes, and no alarms active	NEVER_ON	Off permanently	ALWAYS_ON	On permanently (not recommended)
Setting	Backlight is ...										
MANUAL	On when any key is touched Off when no key touched for 5 minutes										
AUTO	On when any key is touched or alarm is active Off when no key touched for 5 minutes, and no alarms active										
NEVER_ON	Off permanently										
ALWAYS_ON	On permanently (not recommended)										



SYSTEM

System pages provide version information and configure the internal clock, security access, communication protocols, and to reset various memory defaults.

System Access Page

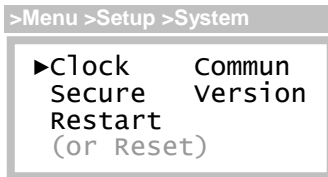

The System Access page provides links to the clock, security, communications, and version pages (the Reset link has been replaced with the Restart function on transmitters beginning with version 2.23).

Figure 58. System access page

Real-time Clock

Clock Setup Page

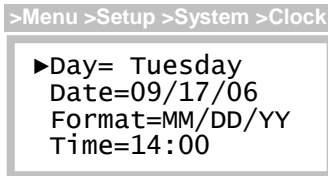

The Clock Setup page is used to set the transmitters real-time clock, which is referenced during sensor calibrations and data logging, and used to trigger Auto-test.

Figure 59. Clock setup page

Variables	Description
Day	Monday, Tuesday, Wednesday, Thursday, Friday, Saturday, and Sunday
Date	Used to configure the month, date, and year, in the format specified by the Format variable (below). Built-in support for leap year.
Format	Selects the date format: MM/DD/YY, example: 09/19/06 DDMMYY, example: 09Sep06
Time	24-hour format, 00:00 to 23:59



Security

The transmitter protects its configuration using a 4-digit, numeric password, from 0000 to 9999. When security is active, the “S” status indicator appears on the Main Display, variables may be read, but not modified, and functions will not execute, including the sensor verification function during startup review.

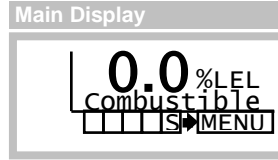

Security Control Page

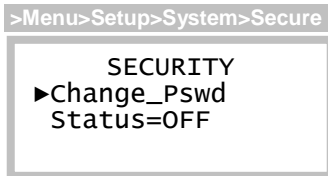

Security is off by default, and may be toggled on and off by entering the 4-digit password.

Figure 60. Security control page

Activating Security

Select the Status variable on the Security Control page, which doubles as a link to the Password Entry page. When the page appears, select Enter Pswd, scroll to the password value (0 by default), and touch Enter. If successful, “PASS” appears briefly and you are returned to the Security Control page where the Status variable is set to ON. If not successful, “FAIL” appears and Status remains OFF.

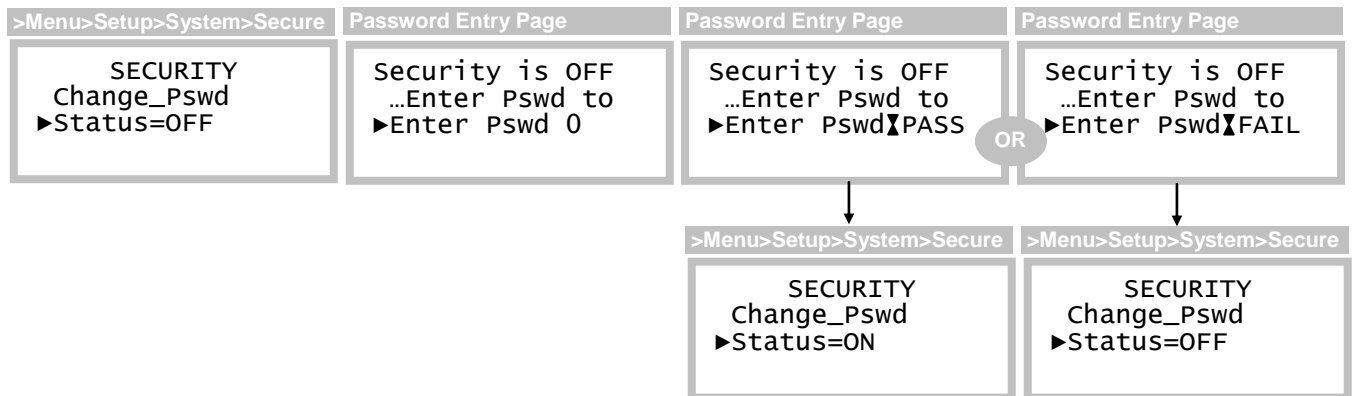

Figure 61. Activating security

Deactivating Security

The procedure to deactivate security is identical to that used for activating it, and if successful, the transmitter presents an option to automatically reactivate it after a timed interval.

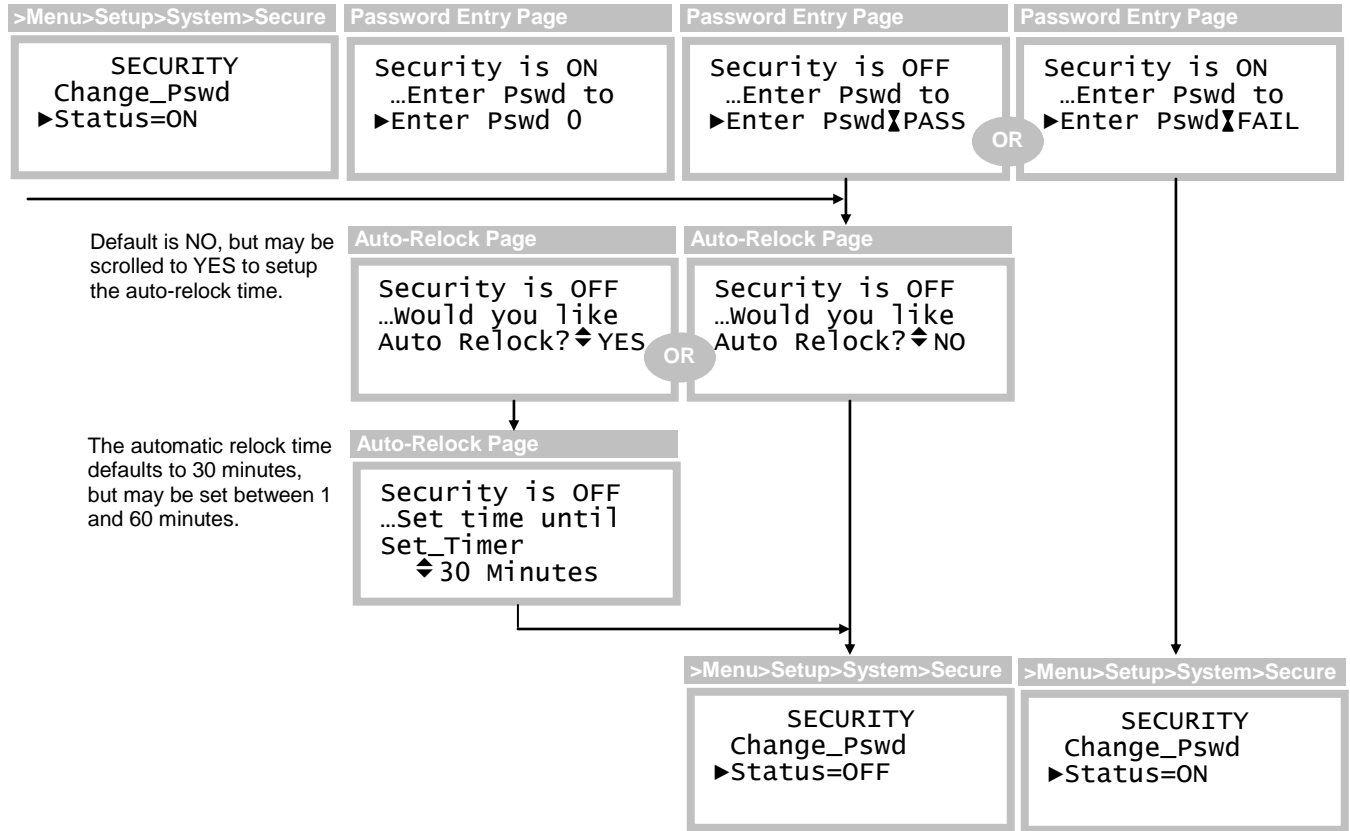

Figure 62. Deactivating security

Changing the Password

The security password is changed by selecting Change_Pswd from the Security Control page. Start by entering the old password, then enter the new one, and repeat it.

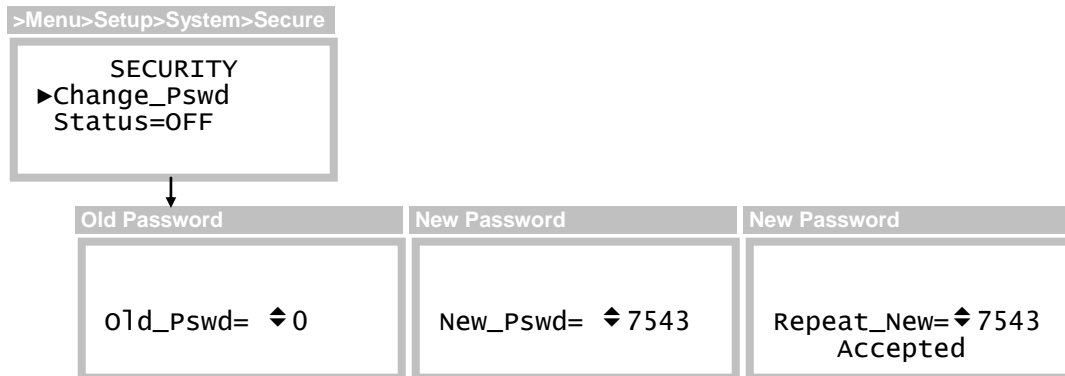

Figure 63. Changing the password



Communications

The D12 Transmitter supports ASCII, HART 5, and Modbus communications. ASCII is the default protocol if the HART or Modbus option is not ordered.

Communication Setup Page

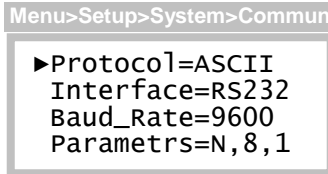

Communication Setup page variables are used to configure the protocol and settings of the physical communication interface. The protocol selection is performed at the factory, and may not be changed. Settings for the physical communication interface may be changed for ASCII and Modbus protocols, however, they are restricted for the HART protocol).

Figure 64. Communication setup page

Table 17. Communication setup variables

Variables	Description
Protocol	The Protocol variable identifies the installed protocol driver: <ul style="list-style-type: none"> • None • ASCII (default) • Modbus (option) • HART (option)
Interface	The Interface variable selects the physical communication interface that the transmitter will control during transmit and receive functions: <ul style="list-style-type: none"> • RS232 (available for ASCII or Modbus, not for HART) • RS485 (available for ASCII or Modbus, not for HART) • MODEM (available for HART only) <p>The transmitter must be wired in accordance with this selection (see Electrical Connections starting on page 11).</p>
Baud_Rate	The Baud_Rate variable is used to configure the baud rate of the transmitter's UART, and may be set to: 300,600,1200,2400,4800,9600,14.4k, or 28.8k <p>The value is fixed at 1200 for HART protocol, and defaults to 9600 for Modbus and ASCII.</p>
Paramtrs	The Paramtrs variable is used to configure parity, the number of data bits, and number of stop bits of the transmitter's UART: <ul style="list-style-type: none"> • N,8,1 ...no parity, 8 data bits, 1 stop bits • N,8,2 ...no parity, 8 data bits, 2 stop bits • E,8,1 ...even parity, 8 data bits, 1 stop bit • O,8,1 ...odd parity, 8 data bits, 1 stop bit <p>The value is fixed at O,8,1 for HART protocol, and defaults to N,8,1 for Modbus and ASCII.</p>



Protocol specific settings are configured on separate pages that are accessible from links on the Setup page, and are discussed below.

ASCII

ASCII is used for sending the data log to a serial printer, terminal, or terminal program, using RS232 (RS485 might be used under certain conditions). Handshaking is XON/XOFF only, and the Communication Setup page may be used to configure the interface, baud rate, and communication variables. See RS232 Modbus, PC Capture, or Printer for connection details. There are no additional pages for protocol variables.

HART

HART is a master/slave protocol that supports 1 or 2 masters, and up to 15 slave devices. Devices communicate digitally at an effective rate of 1200 baud by modulating the 4-20mA loop. Modulation is performed by a modem that conforms to the BELL 202 standard, which uses FSK (frequency shift keying), where 1200Hz represents a logic 1, and 2200Hz represents logic 0, and does not affect the loop’s DC level. Connections are typically point-to-point, which enables bi-directional digital communication and preserves the transmitter’s analog output signal. Up to 15 devices may be connected in a multi-drop configuration for digital communication, but requires each device to fix its output at 4mA. See HART Transmitter connection examples in Electrical Connections starting on page 11, or consult the HART Foundation (www.hartcomm.org) for details on how to connect a HART transmitter.

When the HART protocol driver is installed, a link to the HART Setup page appears on the main Setup page.

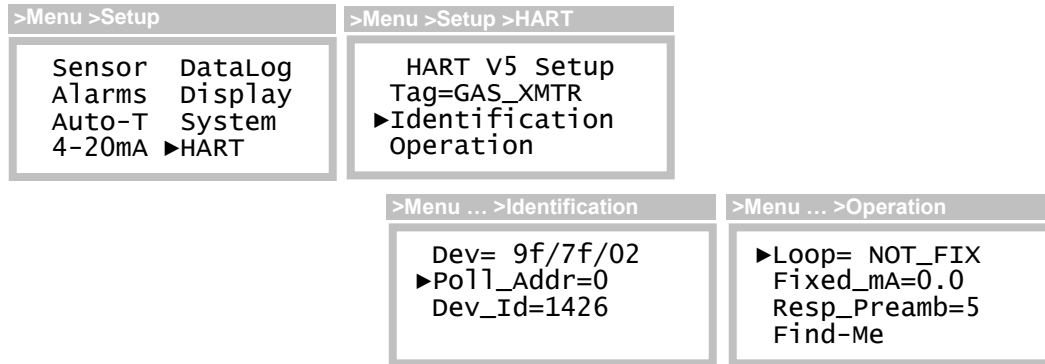

Figure 65. Hart setup pages

Table 18. HART setup variables

Variables	Description
Tag	The Tag variable can be used as a unique identifier for communicating to the transmitter. The variable is read only at the operator interface, but may be modified using HART network management commands.
Dev	The Dev variable displays read-only device information used in long-frame address commands, and by devices capable of utilizing the transmitter’s DDL (device description language) file. The format of the information is, MFG_ID/DEV/REV. The MFG_ID is 9f, and identifies Analytical Technology, Inc as the manufacturer. DEV is 7f, and identifies the device as a D12 transmitter. REV is the revision level of the transmitter, currently set at 2 (may increment in the future).

Poll_Addr	The Poll_Addr variable sets the polling address of the transmitter. The default value is 0, which allows the transmitter to communicate digitally, while preserving the function of the 4-20mA output. The value may be set from 1 to 15, which fixes the output at 4mA, and disables analog signaling.
Dev_Id	The Dev_Id variable is used to form a unique identifier in the HART long frame address. This value is set at the factory, and appears on a label attached to the transmitter. Changing this setting is not recommended.
Loop	The Loop variable specifies the operation of the 4-20mA output. When the HART polling address is 0, the value is NOT_FIX and loop functions as normal. When the address is set to 1 or higher, the value is FIXED and the output is fixed at 4mA. The ability to alter this behavior is reserved for future use, and changing this setting is not recommended.
Fixed_mA	The Fixed_mA variable provides direct access the associated HART network management variable. The value is adjustable only when the Loop variable is FIXED, and may be adjusted between 3.5 and 22 mA.
Resp_Preamb	The Resp_Pream variable provides direct access to the associated HART network management variable, which determines the number of preamble characters (FF hex) transmitted at the beginning of each message. The default value is 5, and may be set from 3 to 20. Changing this setting is not recommended.
Find-Me	The Find-Me function places the transmitter into the Find-Me mode, where a master device can issue a command to positively identify the physical location of the transmitter.

Selecting the Find-Me function presents the special page that remains until the master device issues a “Find-Me” command to the transmitter, at which point the display changes to the “Device Found” page.

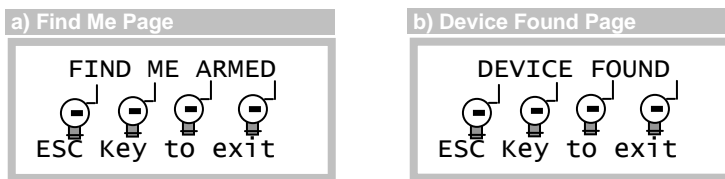

Figure 66. Hart a) Find-me and b) Device found pages



Modbus

Modbus is a master/slave protocol that supports a single master, and up to 247 slave devices on a common bus. The RS485 interface physically limits this number to 32 (1 master, 31 slaves), and RS232 restricts communication to a master and a single slave. The Communication Setup page may be used to configure the interface, baud rate, and communication variables. See RS485 Modbus Multidrop and RS232 Modbus, PC Capture, or Printer for connection details.

When the Modbus protocol driver is installed, a link to the Modbus Setup page appears on the main Setup page.

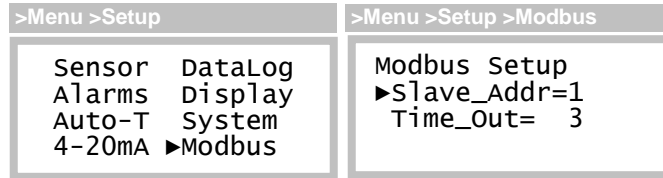

Figure 67. Modbus setup page

Table 19. Modbus setup variables

Variables	Description
Slave_Addr	The Slave_Addr variable is the transmitter's slave address, which may set from 1 (default) to 247.
Time_Out	The Time_Out variable belongs to the data-link layer of the protocol and defines the number of 1.5 character timeouts used to frame messages. This variable is reserved for future use and changing it is not recommended.

Transmitter Version

The Transmitter Version page displays transmitter information:

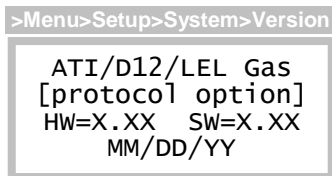

- Line 1: model and version name
- Line 2: protocol option (ASCII,HART,or Modbus)
- Line 3: hardware and software version numbers
- Line 4: software build date

Figure 68. Transmitter version page



Restart

The Restart function will cause the transmitter to start up, just as it does during a power-on-reset. This function replaces the Reset page beginning with version 2.23 of the D12 Combustible Gas Transmitter with Catalytic Bead sensor.

Resets

Note: the Reset page has been removed on software versions 2.23, and higher.

The Reset page provides functions for resetting configuration memories, and restarting the transmitter, which may prove useful for correcting specific faults. These functions should **not be used** unless they are specified in troubleshooting procedures, or directed by authorized factory personnel.

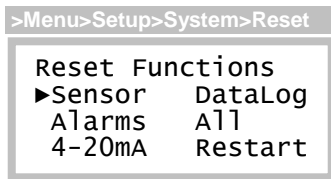

Table 20. Reset functions (do not use except for troubleshooting).

Function	Description
Sensor	Resets zero and span calibration, restarts transmitter. <u>Sensor must be completely recalibrated.</u> On LEL transmitters, calibration and Auto-test history are cleared.
Alarms	Resets alarm set/reset points, options, delays, and inhibit_mA, restarts transmitter.
4-20mA	Resets 4-20mA calibration, loop must be recalibrated, restarts transmitter.
DataLog	Clears the data log history, restarts transmitter.
All	Resets entire transmitter to factory defaults, excluding sensor, restarts transmitter. <u>Requires full transmitter setup.</u>
Restart	Restarts the transmitter.

SPARE PARTS

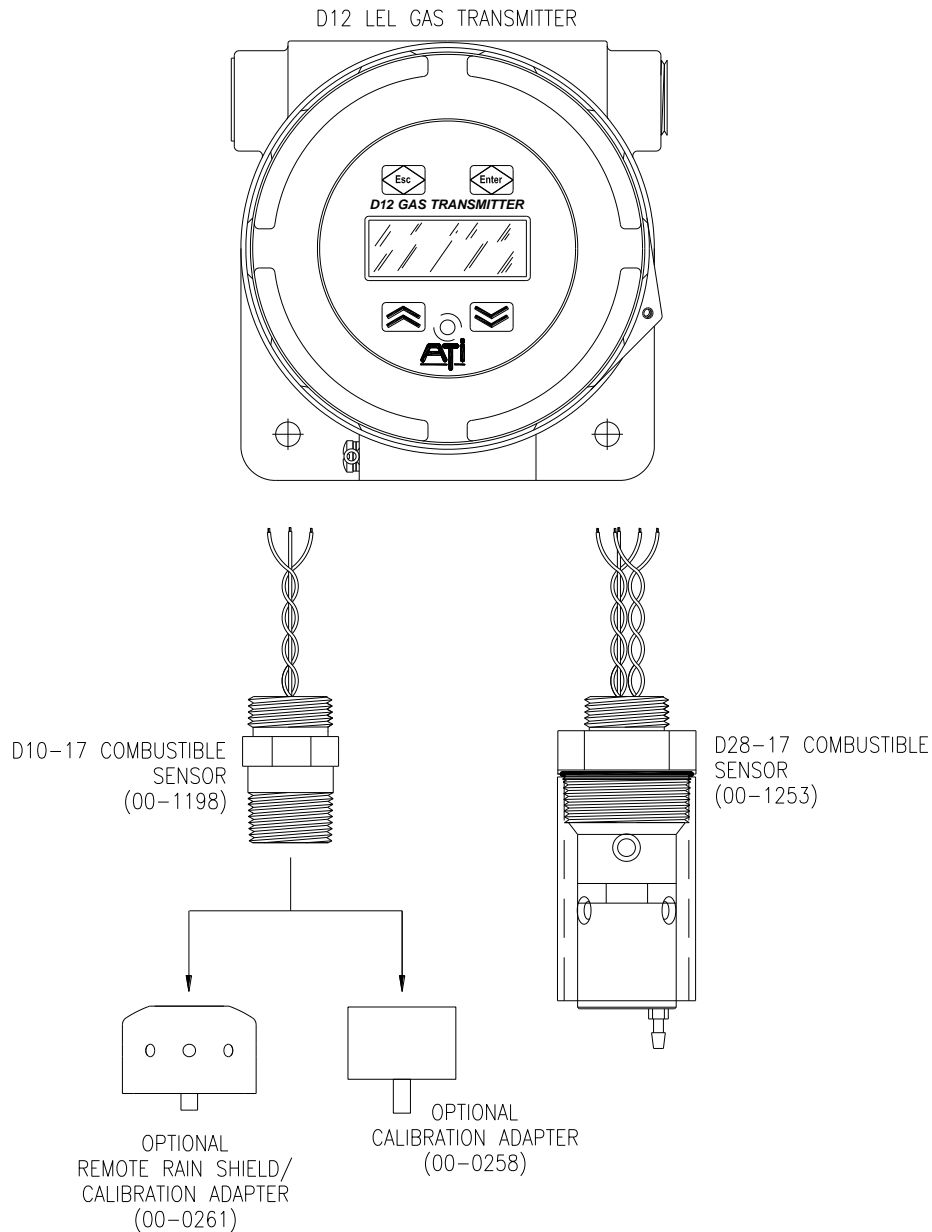

Table 21. Spare parts

Part No.	Description
03-0231	PCB stack assembly (without Relays)
03-0232	PCB stack assembly (with Relays)
00-0258	Calibration adapter (Non-Autotest Version)
45-0081	Splash guard (Autotest Version)
00-0261	Remote Calibration Adapter / Rain Shield (Non-Autotest Version)
29-0007	Battery
55-0004	Magnetic Screwdriver

Appendix A.

Printing Data Log Reports

The following pages describe how to send a data-log report to a printer or computer, over a serial RS232 connection, and to import that data into Microsoft Excel for plotting.

Serial Connection

The data log report may be sent to a printer or a computer over an RS232 connection, or in some cases, an RS485 connection.

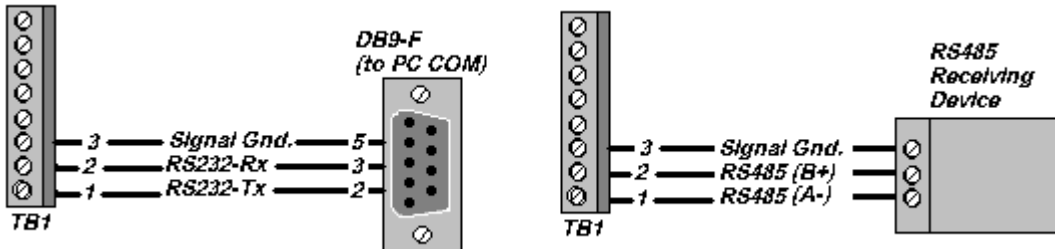

Communication Setup Page

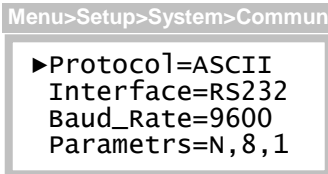

The communication interface, baud rate, parity, number of data bits, and number of stop bits are configured on the Communication Setup page.

Flow Control

The transmitter uses XON/XOFF flow control while sending a report. That is, once the data stream has begun, it will continue until the XOFF character (19) is received. After sitting idle, the report stream will begin again upon reception of the XON character (17).

An RS232 connection can support full duplex communication and is perfectly suited for XON/XOFF flow control. However, an RS485 connection is only half duplex. It cannot receive while it is transmitting and might miss the XOFF character, resulting in a buffer overflow at the receiving device.

A receiving device will send the XOFF character when its buffer is nearly full. Some older dot-matrix printers will send an XOFF because they have a small receive buffers and cannot process characters while the head is returning to start a new line. On the other hand, most computers have comparatively large buffers and can easily accept the report stream without sending an XOFF. Therefore, an RS485 connection may work for sending reports to a computer.

The D12 features an additional method to help avoid losing data due to buffer overflow problems on receiving devices that lack XON/XOFF capability (or have the capability but are using an RS485 connection). A programmable time delay of up to 10s may be inserted at the end of each report line. This permits the receiver time to process more characters in its buffer and avoid an overflow. However, this may be a method of trial and error until the proper delay setting is determined so that no characters are missing from the report.



Report Format

The format of the report is suitable for import into most spreadsheet programs and consists of a date column, a time column, and 1-30 columns for sample values. Each line of the report shows the date and time of the first sample. Samples appearing in subsequent columns (left to right) were recorded at equal sampling intervals.

In the top line of the example below, the first sample (S0) occurred at 22:40. The next sample to the right (S1) occurred at 22:41, followed by the next (S2) at 22:42, and so on. This pattern is repeated throughout the report.

Date	Time	S0	S1	S2	S3
07/09/06	22:40	0.01	0.00	0.02	0.01
07/09/06	22:44	-0.0	0.00	0.00	-0.0
07/09/06	22:48	0.01	TEST	TEST	TEST
07/09/06	22:52	TEST	TEST	TEST	TEST
07/09/06	22:56	TEST	TEST	TEST	TEST
07/09/06	23:00	0.07	0.06	0.07	0.06
07/09/06	23:04	0.06	0.05	0.06	0.06
07/09/06	23:08	0.05	0.05	0.04	0.05
07/09/06	23:12	0.06	0.05	0.05	0.04
07/09/06	23:16	0.01	0.01	0.01	0.00
07/09/06	23:20	0.00	0.00	0.00	-0.1
07/09/06	23:24	-0.0	0.00	0.00	0.00
07/09/06	23:28	----	----	----	----
07/09/06	23:32	----	----	----	----
07/09/06	23:36	----	----	----	----
07/09/06	23:40	FFFF	FFFF	0.02	0.02

The transmitter permits selection of either a CR (carriage return) or CR/LF (carriage return/line feed) as the EOL (end-of-line) characters. If the lines of the report appear to be printing over each other, choose the CR/LF option. If the lines appear to be double spaced, choose the CR option.

The number of sample columns appearing across the page is programmable from 1 to 30. This is designed so that a report may be directed to either a small carriage printer, or to a wider format device. A wider report will take less time to print because the date and time fields will be printed less frequently.

Samples reported are assumed to be in units of PPM, PPB, %, or %LEL, as determined by the gas concentration units appearing on the main display of the transmitter. Sample values outside of printing limits are forced to the following values.

Samples ...	Are forced to...
Less than -999	-999
Greater than 9999	9999

Symbols may appear in place of sample values, and are defined as follows.

Symbol	Description
----	No sample recorded. The transmitter was not on to record the sample, or has not yet recorded the sample.
FFFF	The transmitter was in fault during the sample.
TEST	The transmitter was in auto-test during the sample. This symbol appears only if the Log_Data variable in the Menu/Setup/Auto-T/Setup menu is set to "NO".
****	Data in the log is corrupted or unreliable.

Report Control

The start date and length of the report may be controlled from the operator interface. The length of the report is limited to the number of days actually stored in the log. The report always begins at 00:00 on the start date, and continues forward for the number of days specified. If no data has yet been logged, the report will show four dashes (----) in place of samples.

Example: Charting a Data Log Report

Start HyperTerminal by clicking **Start**, pointing to **Programs**, pointing to **Accessories**, pointing to **Communications**, clicking **HyperTerminal**, and then double-clicking **Hypertrm.exe**.

When the **Connection Description** dialog box appears, type in **Connect To D12**. If you wish, choose an icon by sliding the horizontal scroll bar over and clicking one of the selections. Click **OK** when ready.



When the **Connect To** dialog appears, set **Connect using:** to **Direct to Com1** (or Direct to Com2 if you are using COM2) and click **OK**.





When the **COM1 Properties** dialog box appears, configure the Port Settings as shown below and click **OK**.

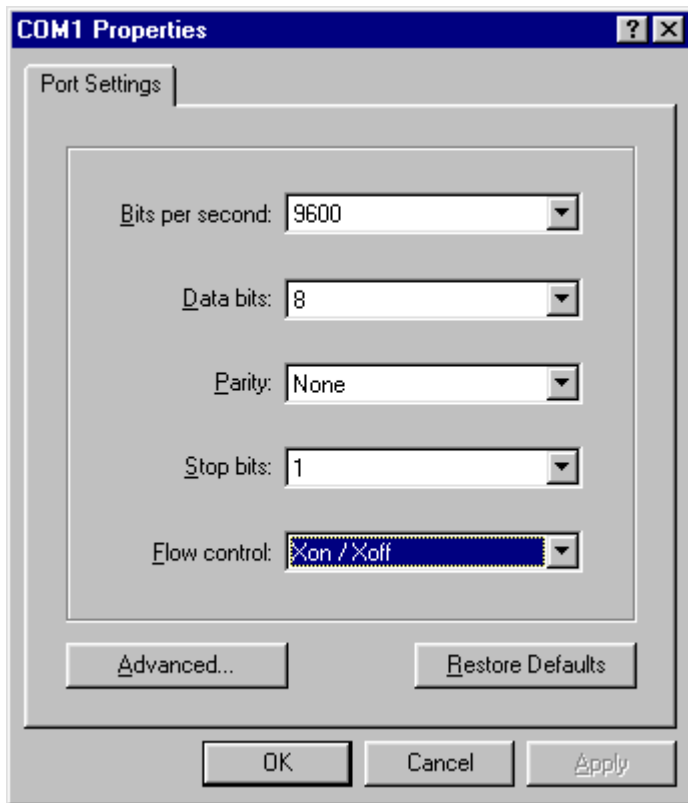

Click **View**, then click **Font** and configure the font settings as shown. This will insure that the data is presented in the terminal window without wrapping from line to line. You may need to experiment with these settings to obtain an acceptable presentation in the terminal window.

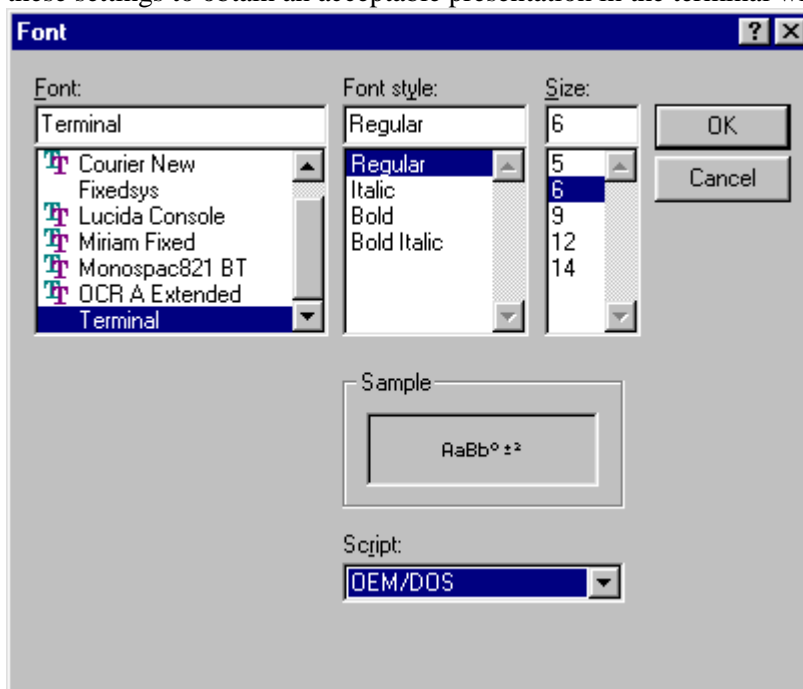

Click **OK** when finished.



Click **File**, then click **Save As**, and click the **Save** button to store the settings as a HyperTerminal session file named Connect To D12.ht (the filename should automatically appear). You may later place this file on your desktop and simply click it to get this point automatically.

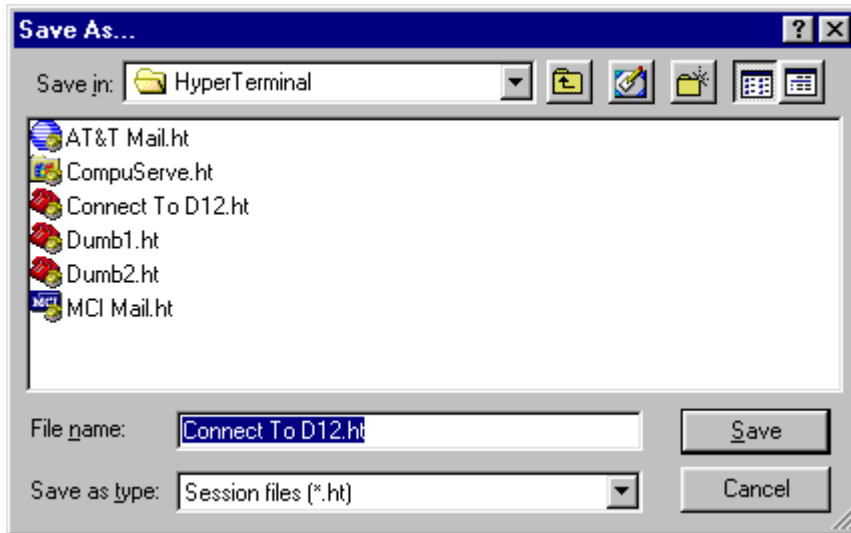

In order to chart the report data, it must be “captured” in a file and given a name. Click **Transfer** on the menu bar, click **Capture Text**, and then click the **Browse** button. Navigate to a folder and type the name of a file to store the report in (or choose an existing file to append the new report).

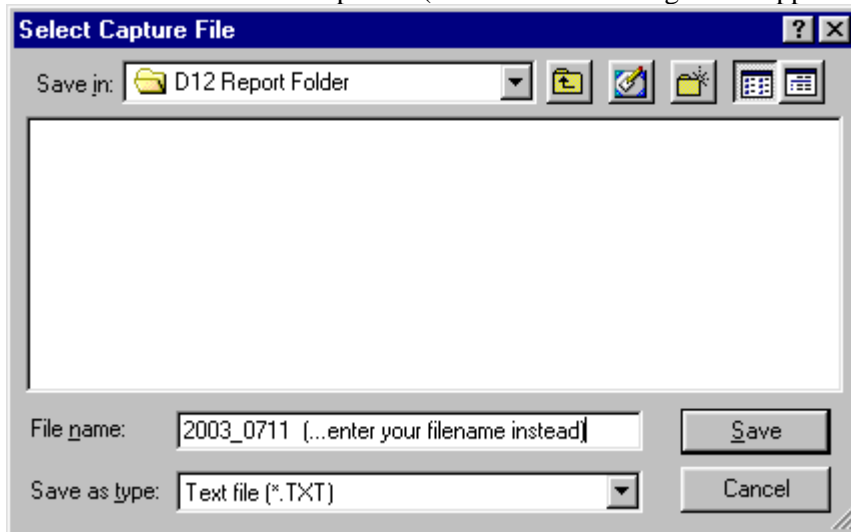

Click the **Save** button to return to the **Capture Text** dialog box. When the **Capture Text** dialog box reappears, click the **Start** button.

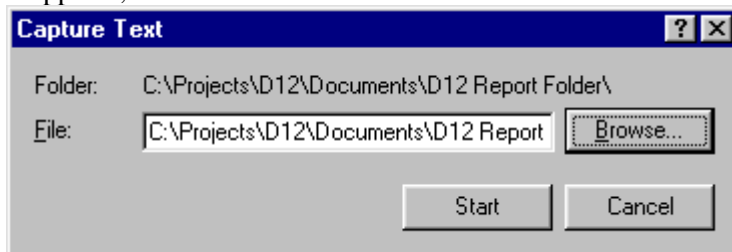



HyperTerminal is now ready to accept a report from the D12 transmitter and save it in a file. Note that data may appear in the terminal window (shown below) if the Connect To D12 session has been run previously, but this data will not appear in the file just opened.

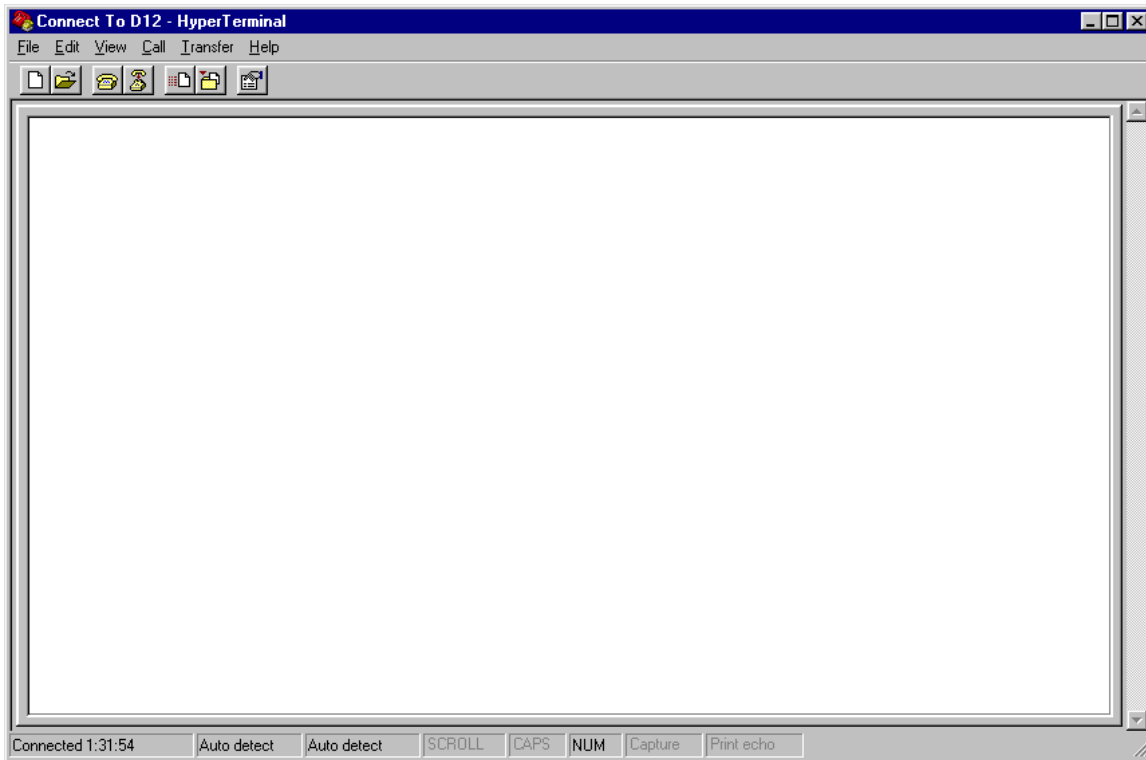

Starting the Report

Prior to sending a report to the computer, the system clock should be set and the data logger turned on to record at least one sample. In addition, the Log_Data variable (in the Menu/Setup/Auto-T/Setup menu) should be set to NO if you prefer to see the symbol TEST and not gas concentration values during auto-test.

Configure the communication variables as shown below. Note that 9600 is the highest baud rate common to the D12 transmitter and the Hyperterminal program.

```
Menu>Setup>System>Commun
▶Protocol=ASCII
Interface=RS232
Baud_Rate=9600
Parameters=N,8,1
```



Navigate to the DataLog page and select Print. You will not be allowed access if there are no samples in the log.

```
>Menu >Setup
Sensor   ▶DataLog
Alarms   Display
Auto-T   System
4-20mA

>Menu >Setup >DataLog
Setup
Review_Tabular
Review_Graphic
▶Print
```

Select the first (starting) date. This will automatically re-compute the maximum number of days shown of the report (variable values will most likely differ from yours).

```
>Menu >Setup >DataLog >Print
▶First=07/13/06
Days= 2 of 2
Page_Setup
Start Printing
```

Edit the Days variable if you prefer to reduce the length of the report, otherwise the entire report will be printed.

```
>Menu >Setup >DataLog >Print
First=07/13/06
▶Days= 1 of 2
Page_Setup
Start Printing
```

Select Page_Setup and configure the Width, Eol, and EolDly variables as shown. The Width variable controls the number of sample columns printed and is settable from 1 to 30. Since the Hyperterminal display is 80 characters wide, set this to 10 columns so that data does not wrap around to the next line. Set Eol for CR/LF, and EolDly to 0.

```
>Menu >Setup >DataLog >Print
▶width= 10 Sampls
Eol=CR/LF
EolDly=0      ms
```

Escape from Page_Setup and select Start_Printing. “Printing” will begin flashing, and you may stop at any time by touching the Esc key.

```
>Menu >Setup >DataLog >Print
First=07/13/06
Days= 1 of 2
Page_Setup
▶Start Printing

>Menu >Setup >DataLog >Print
First=07/13/06
Days= 1 of 2
Page_Setup
Printing
```



The HyperTerminal terminal window should now begin to fill with lines from the report.

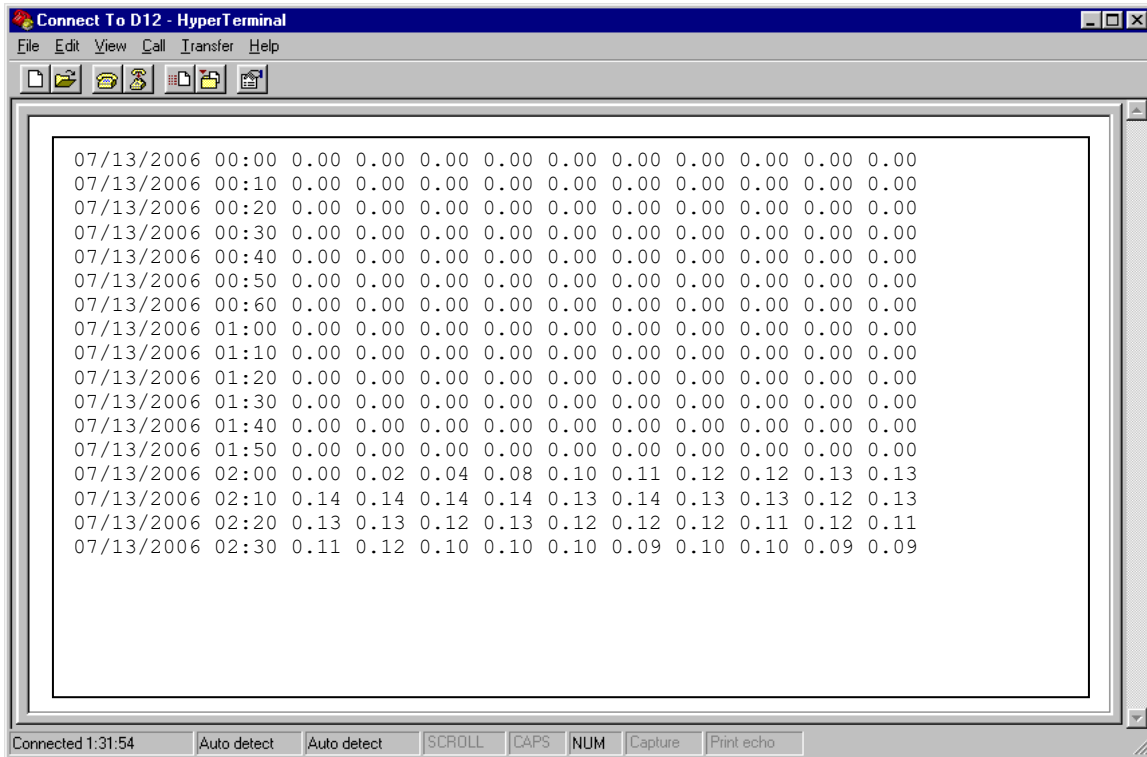

When the transmitter has stopped printing (displays Start_Printing), click **Transfer**, move down to **Capture Text** and click **Stop**. This will close the report file so that it may be opened by another program.



Charting with Microsoft Excel

Microsoft Excel can be used to import data log reports and create useful and informative charts.

Start Excel by clicking **Start**, pointing to **Programs**, and clicking **Microsoft Excel**.

When Excel opens, click **File** and then click **Open**. Navigate to the data log report file you wish to chart and click **Open**. Excel will recognize the report as a text file and offer some configuration options.

When the **Text Import Wizard – Step 1 of 3** appears, configure the settings as shown below and click **Next**. (Note that the values in your report file will be different than those shown below.)

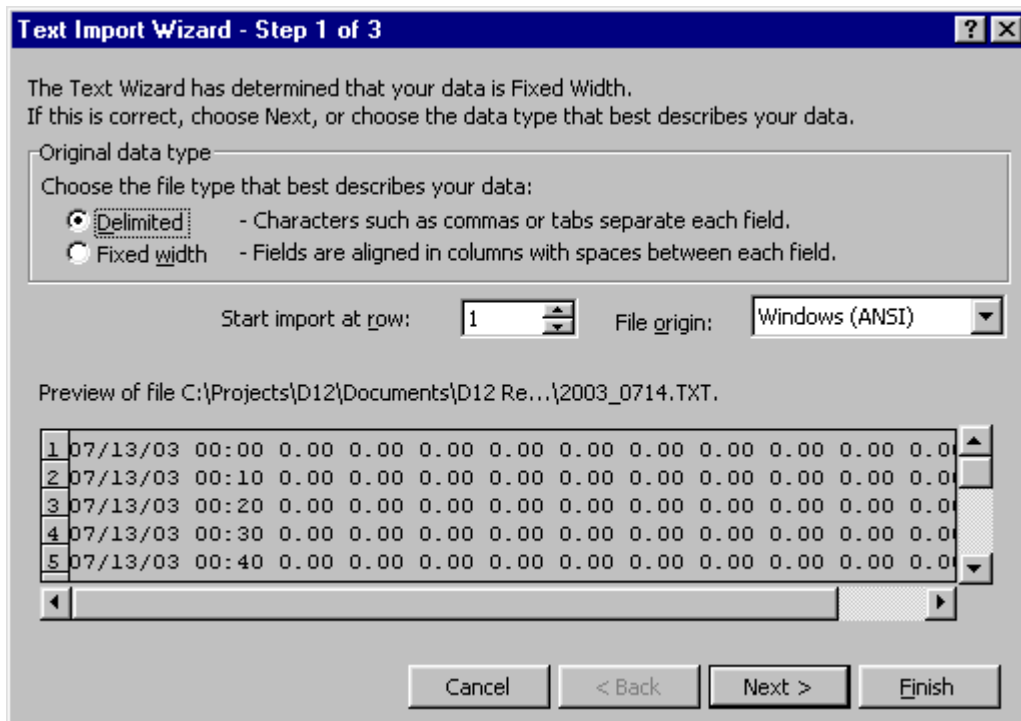



When the **Text Import Wizard – Step 2 of 3** appears, configure the settings as shown below and click **Next**.

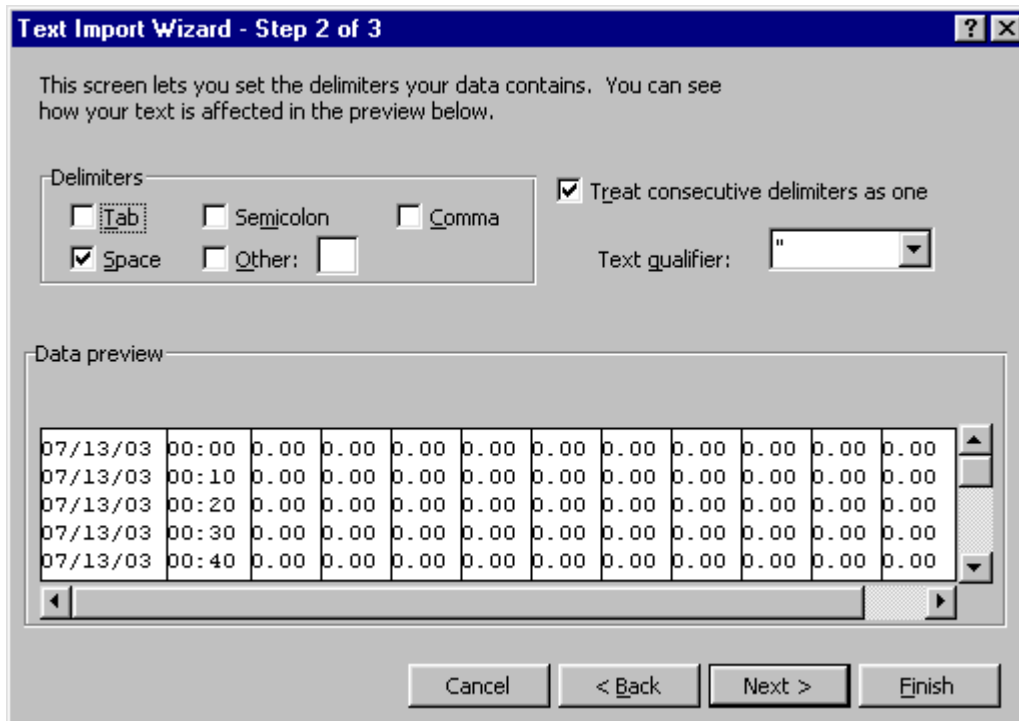

When the **Text Import Wizard – Step 3 of 3** appears, click **Finish**.

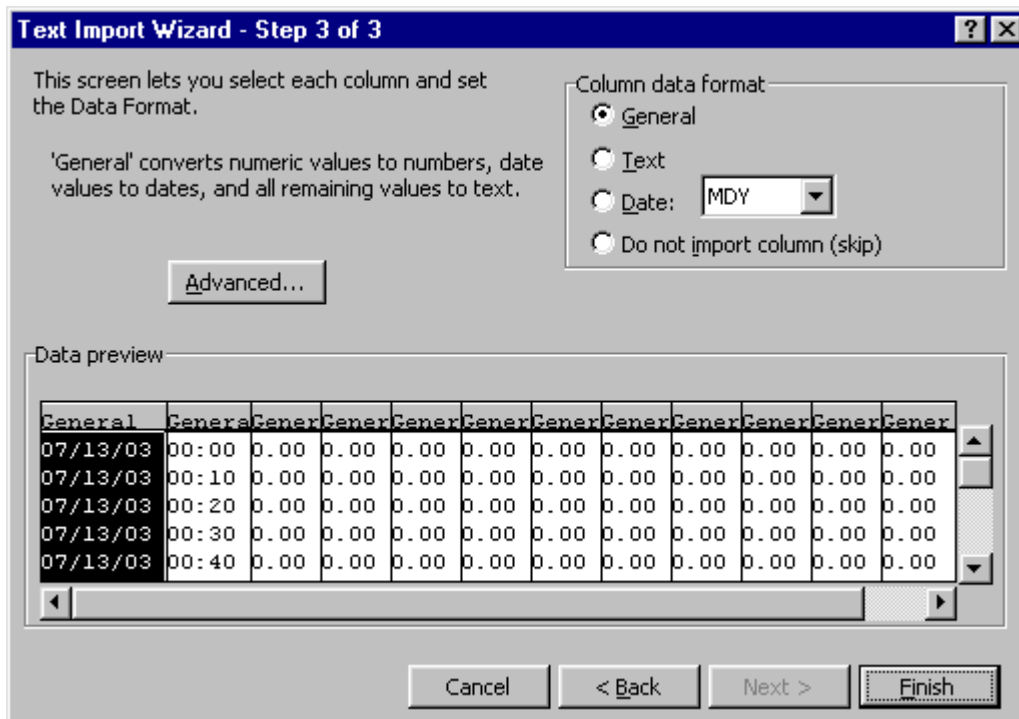



Series D12 LEL Gas Transmitter with Catalytic Bead Sensor

The report should appear as a spreadsheet resembling the format shown below. Of course the dates, times, and values will be different.

	A	B	C	D	E	F	G	H	I	J	K	L	M	N	O
1	7/13/03	0:00	0	0	0	0	0	0	0	0	0	0	0		
2	7/13/03	0:10	0	0	0	0	0	0	0	0	0	0	0		
3	7/13/03	0:20	0	0	0	0	0	0	0	0	0	0	0		
4	7/13/03	0:30	0	0	0	0	0	0	0	0	0	0	0		
5	7/13/03	0:40	0	0	0	0	0	0	0	0	0	0	0		
6	7/13/03	0:50	0	0	0	0	0	0	0	0	0	0	0		
7	7/13/03	1:00	0	0	0	0	0	0	0	0	0	0	0		
8	7/13/03	1:10	0	0	0	0	0	0	0	0	0	0	0		
9	7/13/03	1:20	0	0	0	0	0	0	0	0	0	0	0		
10	7/13/03	1:30	0	0	0	0	0	0	0	0	0	0	0		
11	7/13/03	1:40	0	0	0	0	0	0	0	0	0	0	0		
12	7/13/03	1:50	0	0	0	0	0	0	0	0	0	0	0		
13	7/13/03	2:00	0	0.02	0.04	0.08	0.1	0.11	0.12	0.12	0.13	0.13			
14	7/13/03	2:10	0.14	0.14	0.14	0.14	0.13	0.14	0.13	0.13	0.12	0.13			
15	7/13/03	2:20	0.13	0.13	0.12	0.13	0.12	0.12	0.12	0.11	0.12	0.11			
16	7/13/03	2:30	0.11	0.12	0.1	0.1	0.1	0.09	0.1	0.1	0.09	0.09			
17	7/13/03	2:40	0.09	0.09	0.1	0.09	0.08	0.09	0.08	0.08	0.08	0.07			
18	7/13/03	2:50	0.08	0.08	0.07	0.08	0.07	0.07	0.07	0.06	0.07	0.07			
19	7/13/03	3:00	0.06	0.06	0.06	0.07	0.06	0.06	0.06	0.05	0.05	0.06			
20	7/13/03	3:10	0.05	0.05	0.05	0.05	0.04	0.05	0.04	0.04	0.05	0.04			
21	7/13/03	3:20	0.04	0.04	0.04	0.04	0.03	0.04	0.04	0.04	0.04	0.03			
22	7/13/03	3:30	0.03	0.03	0.03	0.02	0.02	0.02	0.03	0.02	0.02	0.01			
23	7/13/03	3:40	0.01	0.01	0.01	0.02	0.01	0.01	0.01	0.01	0	0			
24	7/13/03	3:50	0	0	0	0	0	0	0	0	0	0			
25	7/13/03	4:00	0	0	0	0	0	0	0	0	0	0			
26	7/13/03	4:10	0	0	0	0	0	0	0	0	0	0			
27	7/13/03	4:20	0	0	0	0	0	0	0	0	0	0			
28	7/13/03	4:30	0	0	0	0	0	0	0	0	0	0			
29	7/13/03	4:40	0	0	0	0	0	0	0	0	0	0			
30	7/13/03	4:50	0	0	0	0	0	0	0	0	0	0			
31	7/13/03	5:00	0	0	0	0	0	0	0	0	0	0			
32	7/13/03	5:10	0	0	0	0	0	0	0	0	0	0			



Series D12 LEL Gas Transmitter with Catalytic Bead Sensor

To chart the report, select one full day of data by dragging the mouse cursor over the region to be charted. Notice that this region begins in the time of day column and extends across each of the sample columns.

	A	B	C	D	E	F	G	H	I	J	K	L	M	N	O
1	7/13/03	0:00	0	0	0	0	0	0	0	0	0	0			
2	7/13/03	0:10	0	0	0	0	0	0	0	0	0	0			
3	7/13/03	0:20	0	0	0	0	0	0	0	0	0	0			
4	7/13/03	0:30	0	0	0	0	0	0	0	0	0	0			
5	7/13/03	0:40	0	0	0	0	0	0	0	0	0	0			
6	7/13/03	0:50	0	0	0	0	0	0	0	0	0	0			
7	7/13/03	1:00	0	0	0	0	0	0	0	0	0	0			
8	7/13/03	1:10	0	0	0	0	0	0	0	0	0	0			
9	7/13/03	1:20	0	0	0	0	0	0	0	0	0	0			
10	7/13/03	1:30	0	0	0	0	0	0	0	0	0	0			
11	7/13/03	1:40	0	0	0	0	0	0	0	0	0	0			
12	7/13/03	1:50	0	0	0	0	0	0	0	0	0	0			
13	7/13/03	2:00	0	0.02	0.04	0.08	0.1	0.11	0.12	0.12	0.13	0.13			
14	7/13/03	2:10	0.14	0.14	0.14	0.14	0.13	0.14	0.13	0.13	0.13	0.12	0.13		
15	7/13/03	2:20	0.13	0.13	0.12	0.13	0.12	0.12	0.12	0.11	0.12	0.11			
16	7/13/03	2:30	0.11	0.12	0.1	0.1	0.1	0.09	0.1	0.1	0.09	0.09			
17	7/13/03	2:40	0.09	0.09	0.1	0.09	0.08	0.09	0.08	0.08	0.08	0.07			
18	7/13/03	2:50	0.08	0.08	0.07	0.08	0.07	0.07	0.07	0.06	0.07	0.07			
19	7/13/03	3:00	0.06	0.06	0.06	0.07	0.06	0.06	0.06	0.05	0.05	0.06			
20	7/13/03	3:10	0.05	0.05	0.05	0.05	0.04	0.05	0.04	0.04	0.05	0.04			
21	7/13/03	3:20	0.04	0.04	0.04	0.04	0.03	0.04	0.04	0.04	0.03	0.03			
22	7/13/03	3:30	0.03	0.03	0.03	0.02	0.02	0.02	0.03	0.02	0.02	0.01			
23	7/13/03	3:40	0.01	0.01	0.01	0.02	0.01	0.01	0.01	0.01	0	0			
24	7/13/03	3:50	0	0	0	0	0	0	0	0	0	0			
25	7/13/03	4:00	0	0	0	0	0	0	0	0	0	0			
26	7/13/03	4:10	0	0	0	0	0	0	0	0	0	0			
27	7/13/03	4:20	0	0	0	0	0	0	0	0	0	0			
28	7/13/03	4:30	0	0	0	0	0	0	0	0	0	0			
29	7/13/03	4:40	0	0	0	0	0	0	0	0	0	0			
30	7/13/03	4:50	0	0	0	0	0	0	0	0	0	0			
31	7/13/03	5:00	0	0	0	0	0	0	0	0	0	0			
32	7/13/03	5:10	0	0	0	0	0	0	0	0	0	0			

After selecting the region, click Insert and then Chart (or click the Chart icon directly from the toolbar).

When the **Chart Type** dialog appears, click on **Column**, and click **Next**.

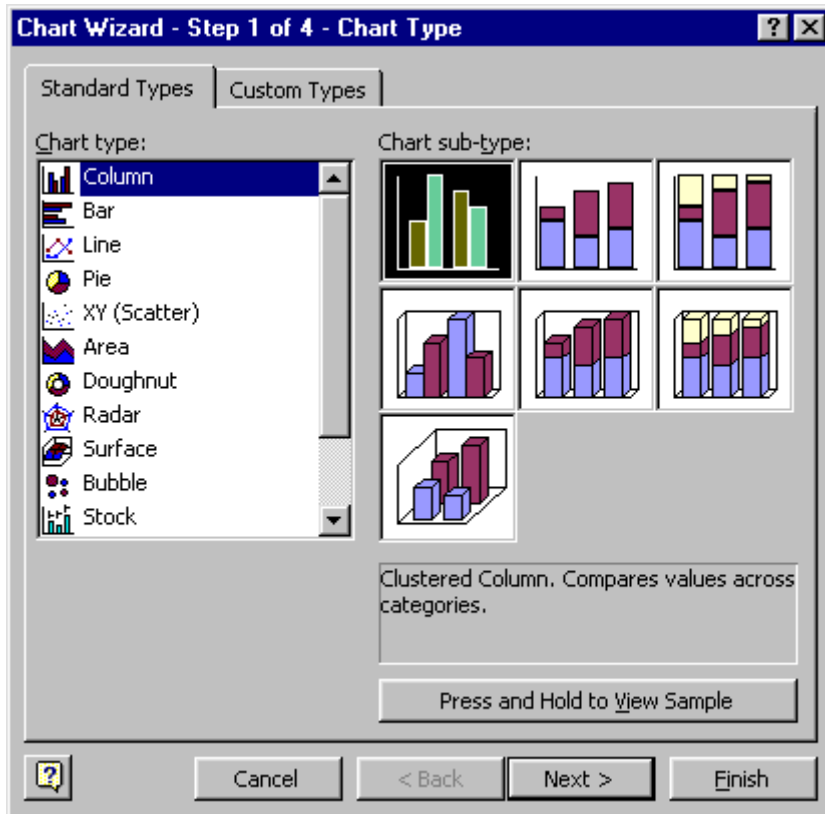



When the **Chart Source Data** dialog appears, click **Next**.

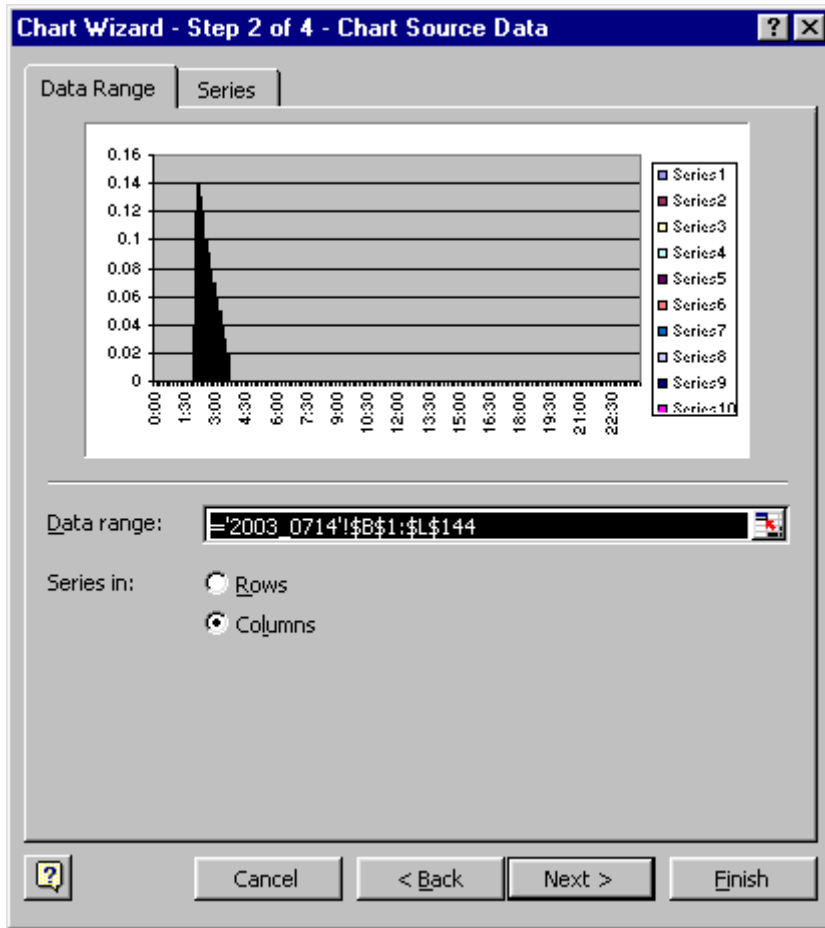

When the **Chart Options** dialog appears, click off the **Show legend** option, and click **Next**.

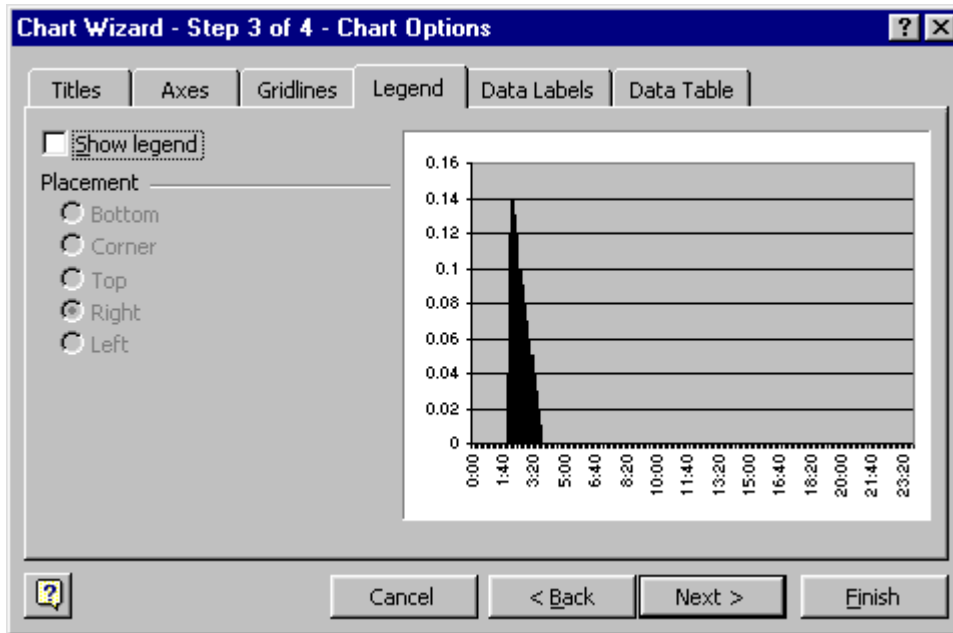

When the **Chart Location** dialog appears, click the **As new sheet** radio button and enter the name of a new sheet to store the chart in. Alternately, you may click the **As object in** radio button to place the chart onto the sheet you have just created.

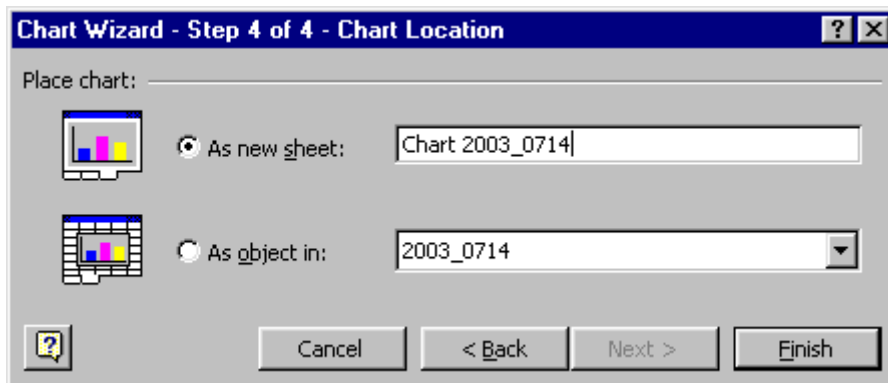



Series D12 LEL Gas Transmitter with Catalytic Bead Sensor

If you have previously clicked the **As new sheet** radio button, the chart will appear on the new sheet named above. You may now move between the new sheet and the old sheet by clicking the sheet tabs that appear just below the chart display.

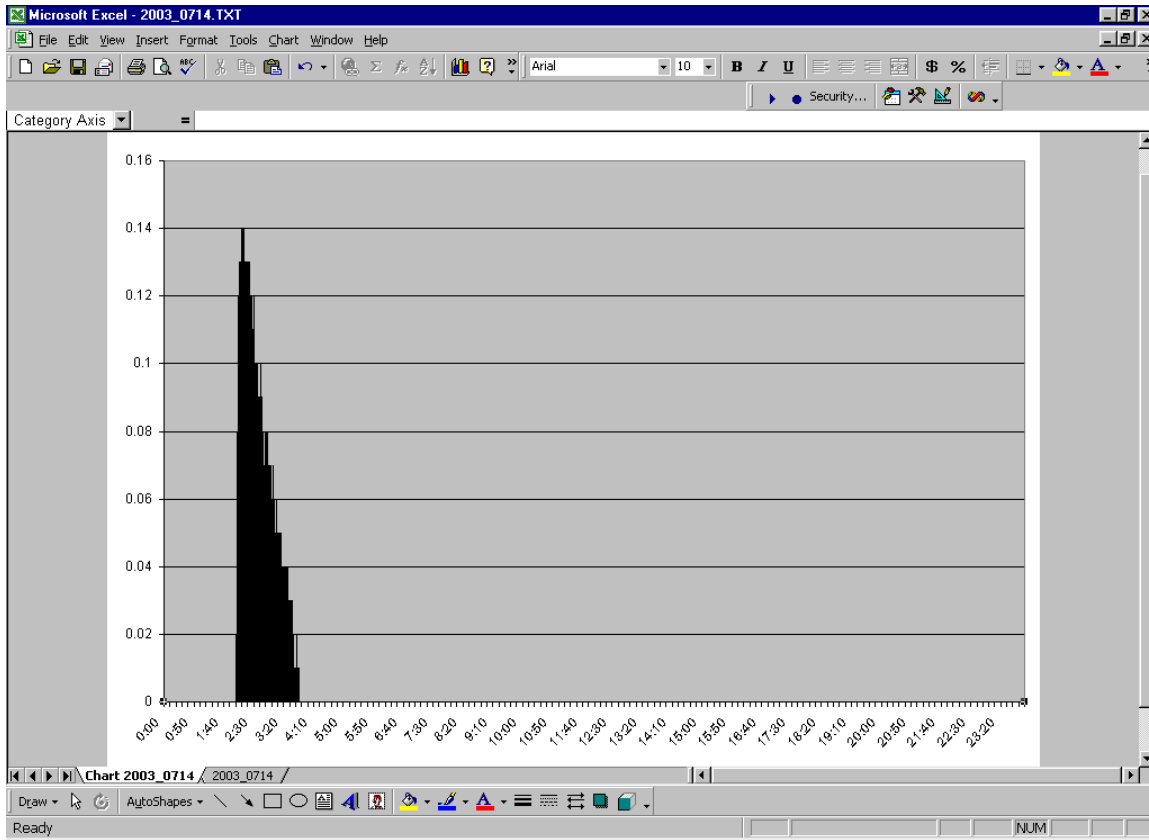



If you have previously clicked the **As object in:** radio button, the chart will appear on the existing sheet.

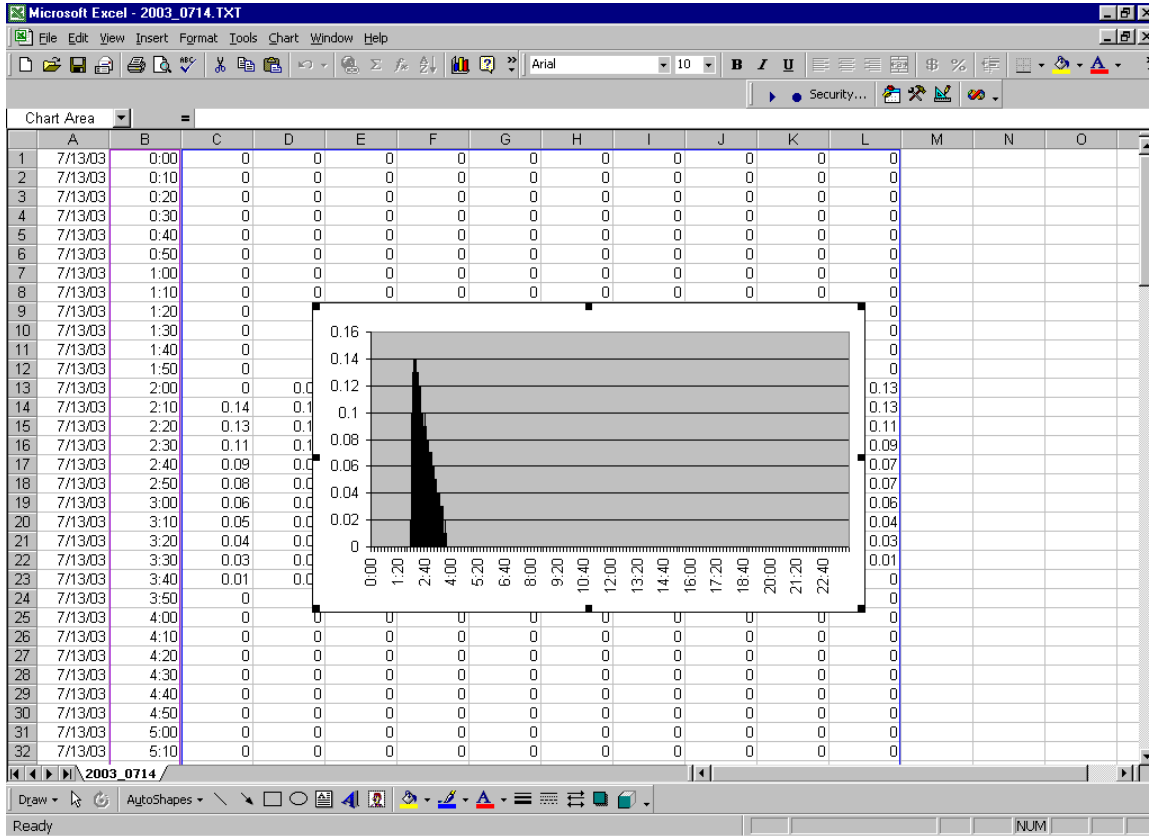

Finally, click **File**, then **Save** to store the chart.

Once the chart has been created, you may wish to rescale it, title it, and print it. These features are detailed in Microsoft Excel Help and are beyond the scope of this document.



Product Warranty

Analytical Technology, Inc. (Manufacturer) warrants to the Customer that if any part(s) of the Manufacturer's equipment proves to be defective in materials or workmanship within the earlier of 18 months of the date of shipment or 12 months of the date of start-up, such defective parts will be repaired or replaced free of charge. Inspection and repairs to products thought to be defective within the warranty period will be completed at the Manufacturer's facilities in Collegeville, PA. Products on which warranty repairs are required shall be shipped freight prepaid to the Manufacturer. The product(s) will be returned freight prepaid and allowed if it is determined by the manufacturer that the part(s) failed due to defective materials or workmanship.

This warranty does not cover consumable items, batteries, or wear items subject to periodic replacement including lamps and fuses.

Gas sensors carry a 12 months from date of shipment warranty and are subject to inspection for evidence of misuse, abuse, alteration, improper storage, or extended exposure to excessive gas concentrations. Should inspection indicate that sensors have failed due to any of the above, the warranty shall not apply.

The Manufacturer assumes no liability for consequential damages of any kind, and the buyer by acceptance of this equipment will assume all liability for the consequences of its use or misuse by the Customer, his employees, or others. A defect within the meaning of this warranty is any part of any piece of a Manufacturer's product which shall, when such part is capable of being renewed, repaired, or replaced, operate to condemn such piece of equipment.

This warranty is in lieu of all other warranties (including without limiting the generality of the foregoing warranties of merchantability and fitness for a particular purpose), guarantees, obligations or liabilities expressed or implied by the Manufacturer or its representatives and by statute or rule of law.

This warranty is void if the Manufacturer's product(s) has been subject to misuse or abuse, or has not been operated or stored in accordance with instructions, or if the serial number has been removed.

Analytical Technology, Inc. makes no other warranty expressed or implied except as stated above

WATER QUALITY MONITORS

Dissolved Oxygen
Free Chlorine
Combined Chlorine
Total Chlorine
Residual Chlorine Dioxide
Potassium Permanganate
Dissolved Ozone
pH/ORP
Conductivity
Hydrogen Peroxide
Peracetic Acid
Dissolved Sulfide
Residual Sulfite
Fluoride
Dissolved Ammonia
Turbidity
Suspended Solids
Sludge Blanket Level
MetriNet Distribution Monitor

GAS DETECTION PRODUCTS

NH ₃	Ammonia
CO	Carbon Monoxide
H ₂	Hydrogen
NO	Nitric Oxide
O ₂	Oxygen
CO	Cl ₂ Phosgene
Br ₂	Bromine
Cl ₂	Chlorine
ClO ₂	Chlorine Dioxide
F ₂	Fluorine
I ₂	Iodine
H _x	Acid Gases
C ₂ H ₄ O	Ethylene Oxide
C ₂ H ₆ O	Alcohol
O ₃	Ozone
CH ₄	Methane (Combustible Gas)
H ₂ O ₂	Hydrogen Peroxide
HCl	Hydrogen Chloride
HCN	Hydrogen Cyanide
HF	Hydrogen Fluoride
H ₂ S	Hydrogen Sulfide
NO ₂	Nitrogen Dioxide
NO _x	Oxides of Nitrogen
SO ₂	Sulfur Dioxide
H ₂ Se	Hydrogen Selenide
B ₂ H ₆	Diborane
GeH ₄	Germane
AsH ₃	Arsine
PH ₃	Phosphine
SiH ₄	Silane
HCHO	Formaldehyde
C ₂ H ₄ O ₃	Peracetic Acid
DMA	Dimethylamine